

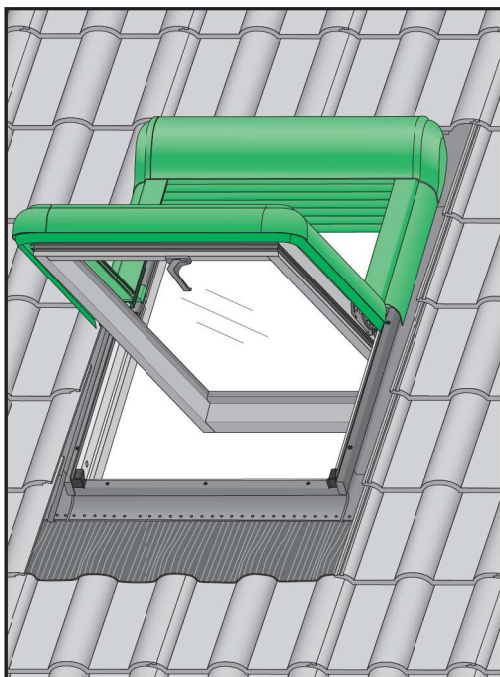

# ARZ WiFi

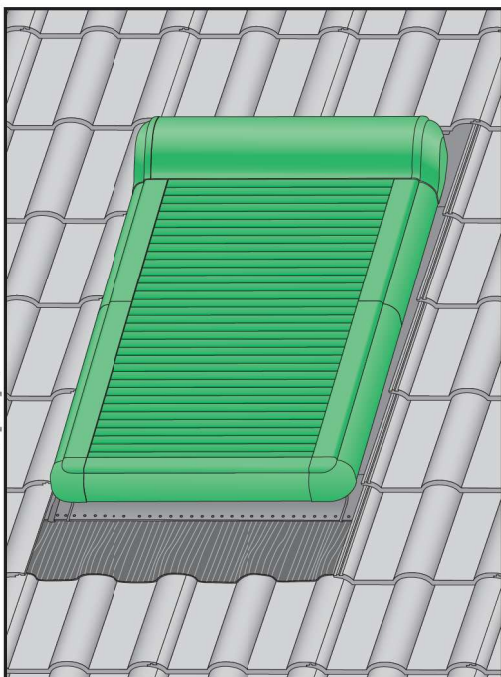

NC 91W\_ARZ\_WIFI\_21.02.12\_FAKRO\_KB2430

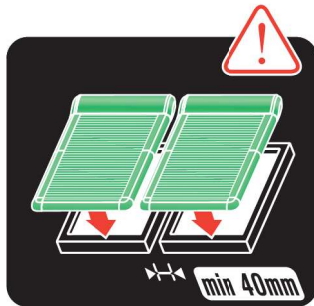

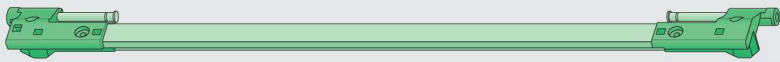
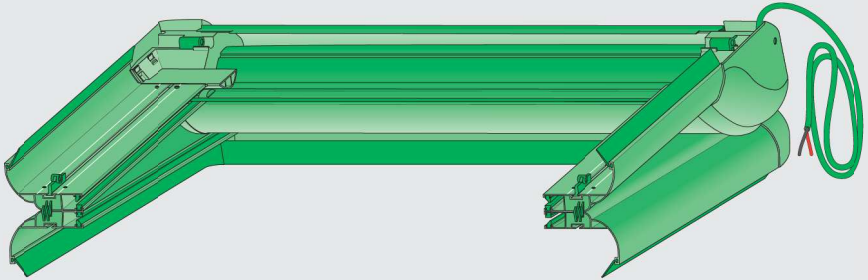

HA 325



HA 324



HA 355



HA 353



HA 329

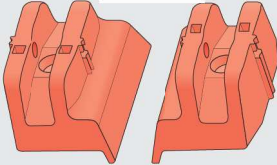

HA 328

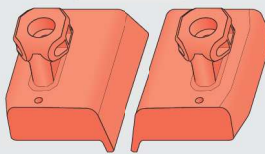

HA 348

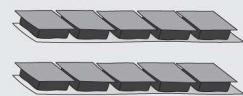
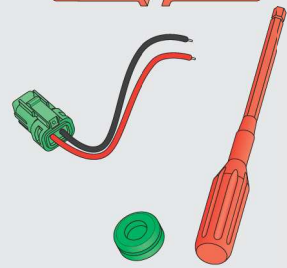
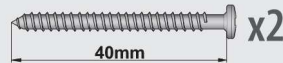
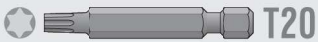

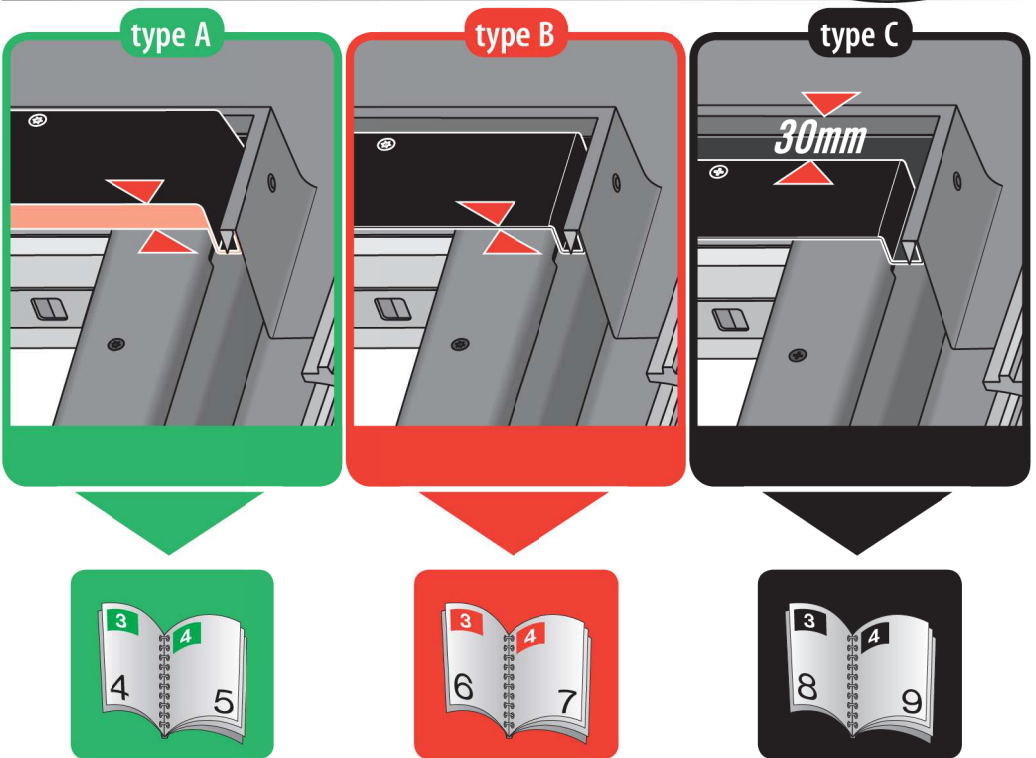
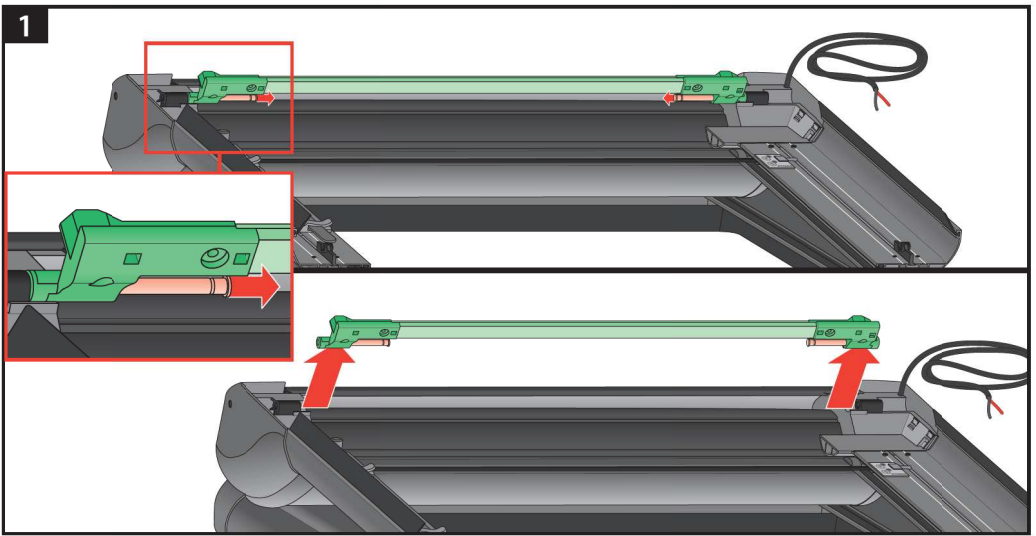

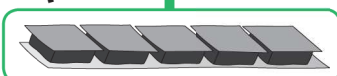
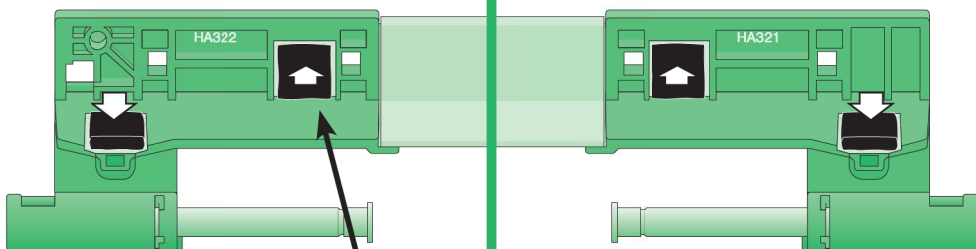
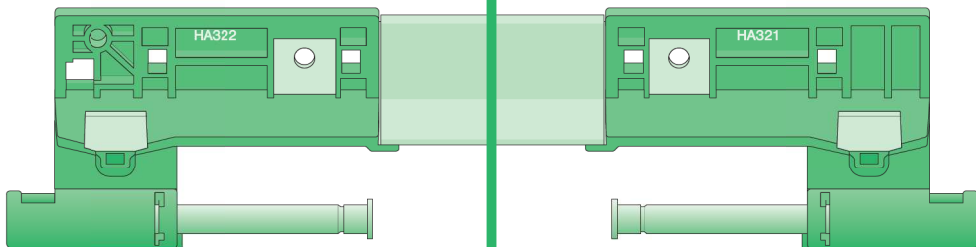

4

type A

1

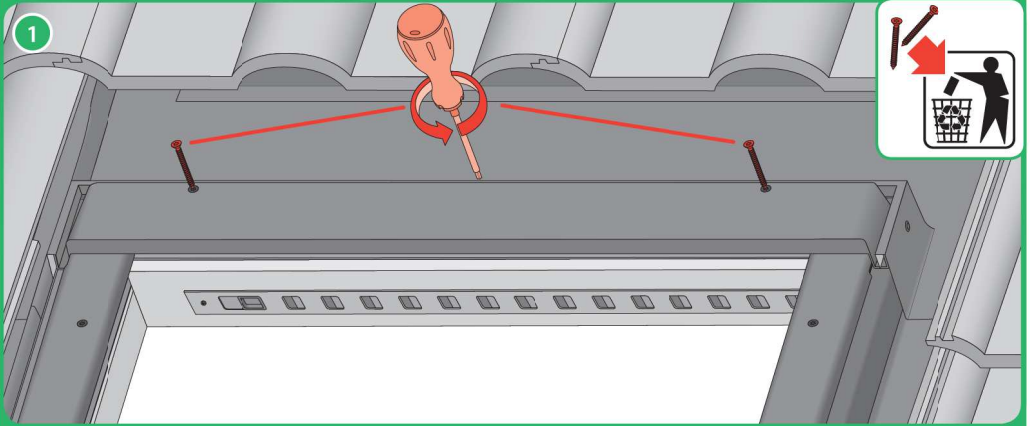

2

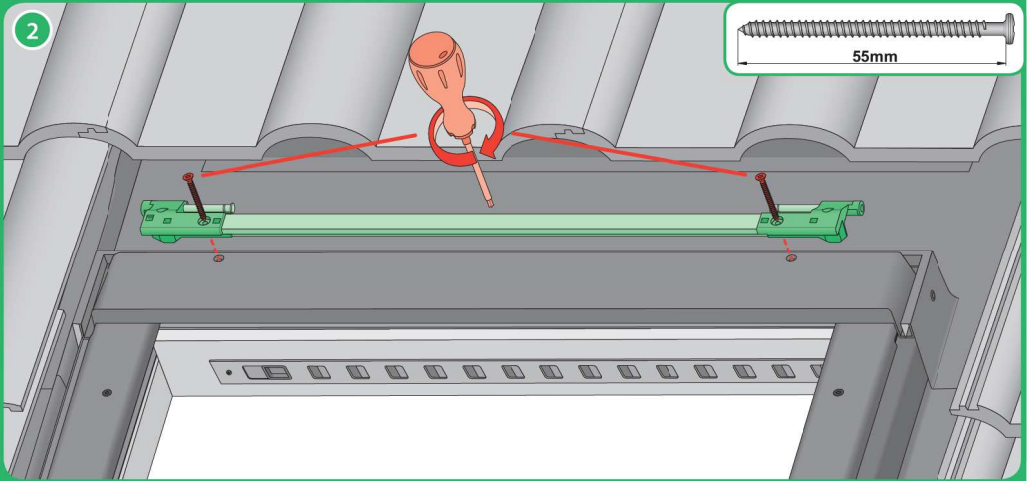

3

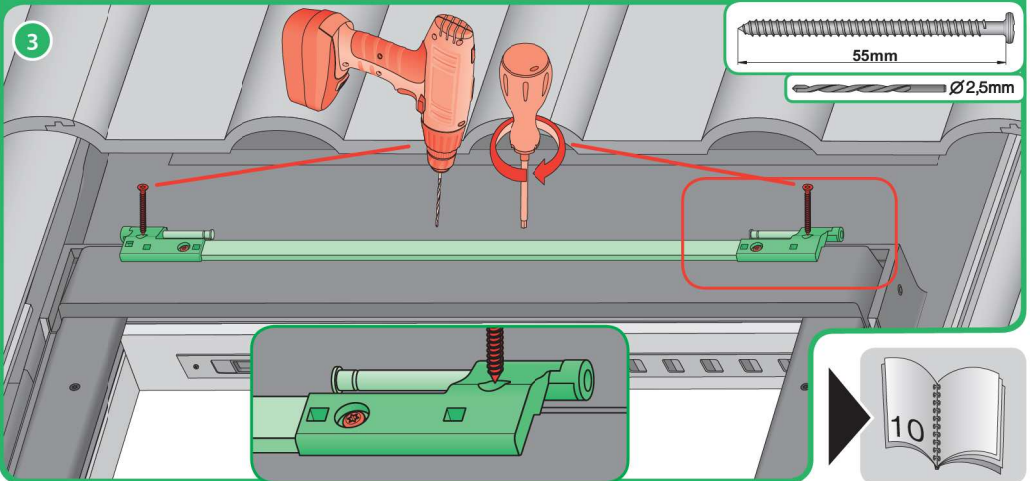

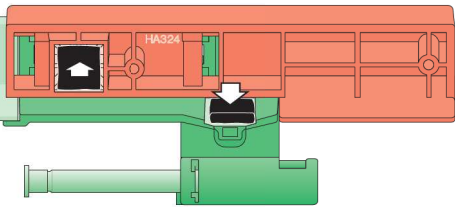
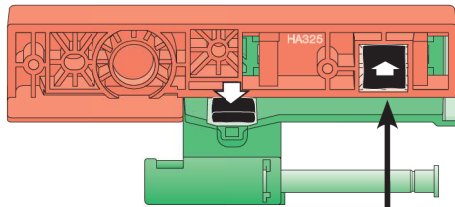
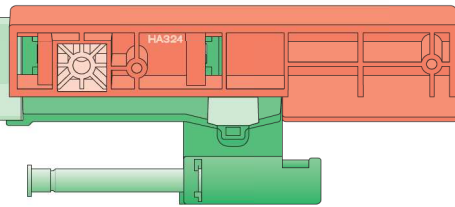
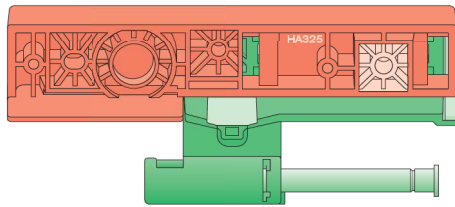
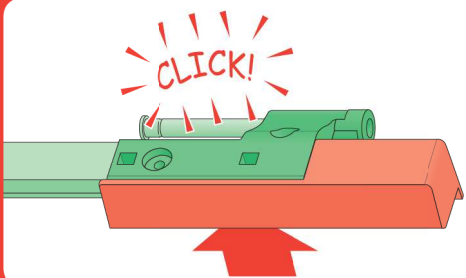
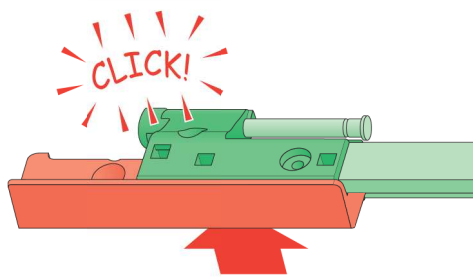

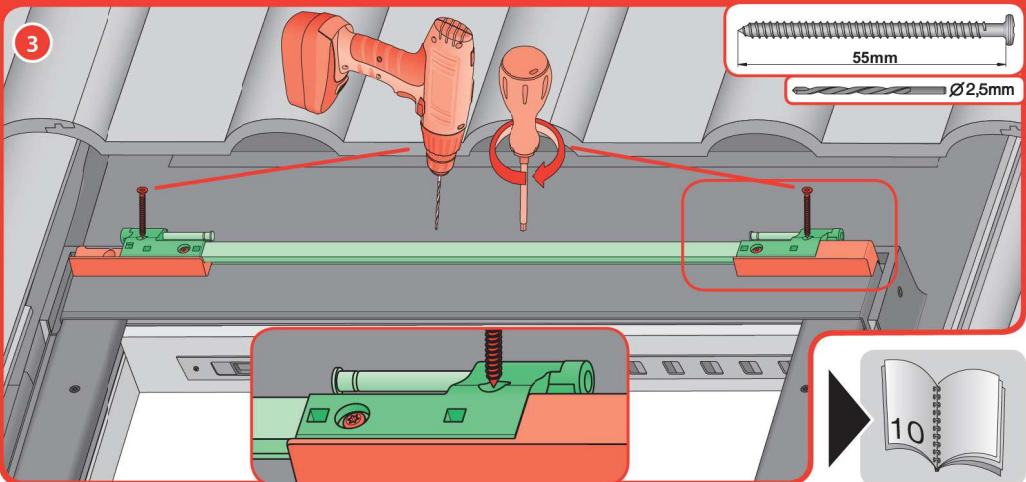
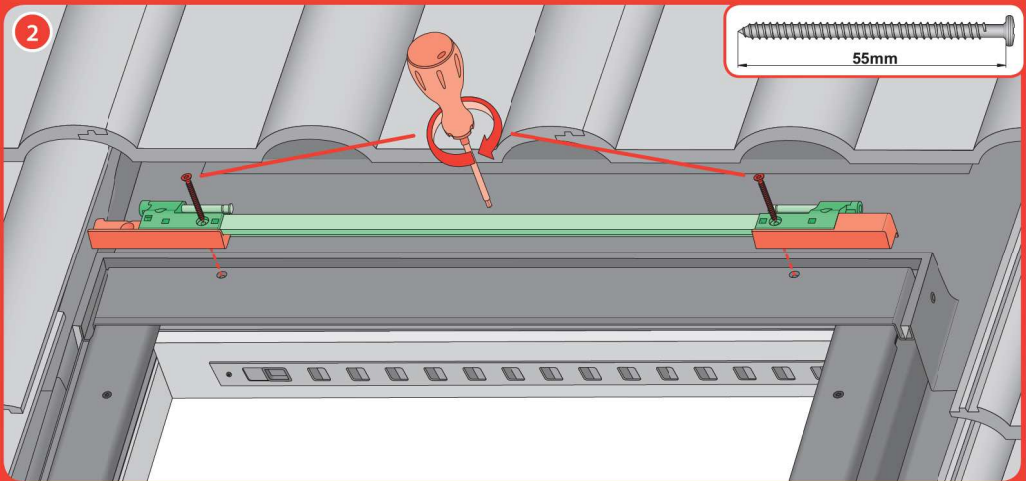
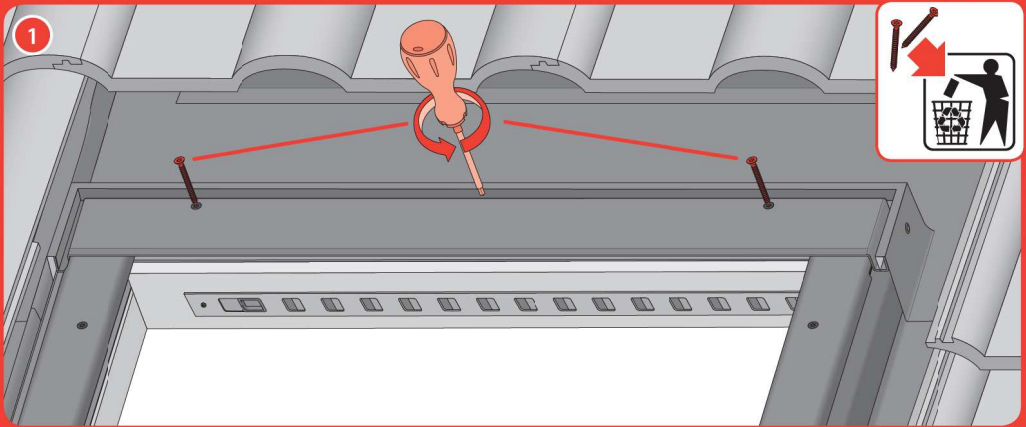

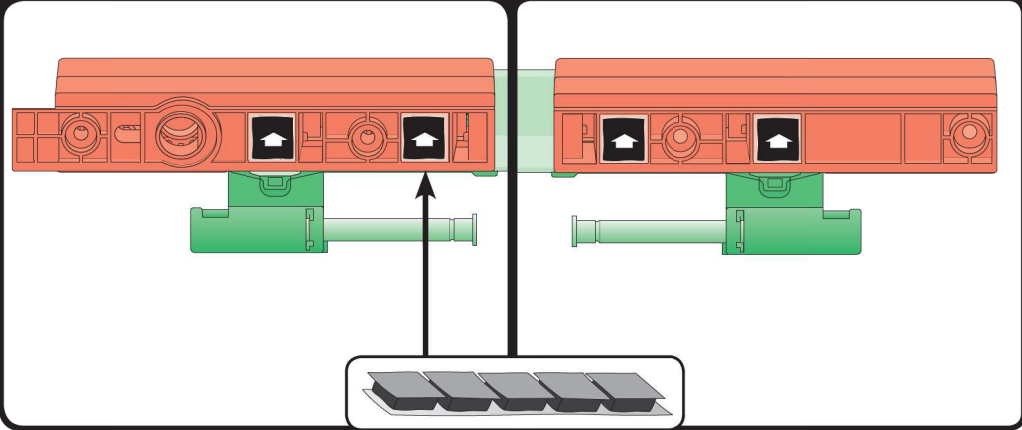
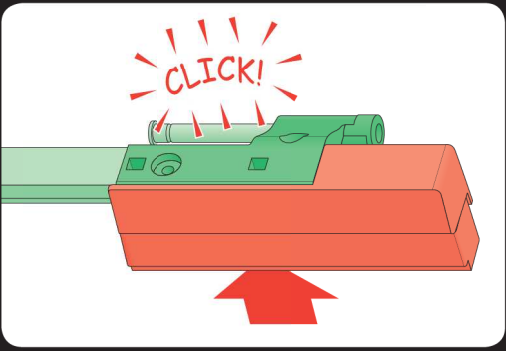
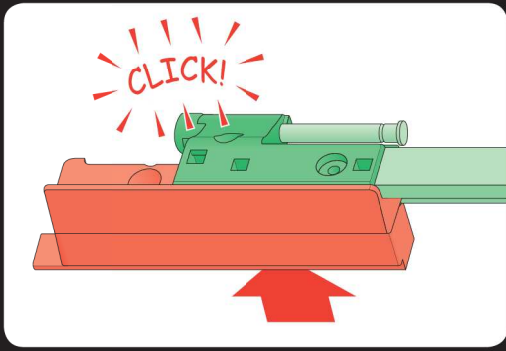
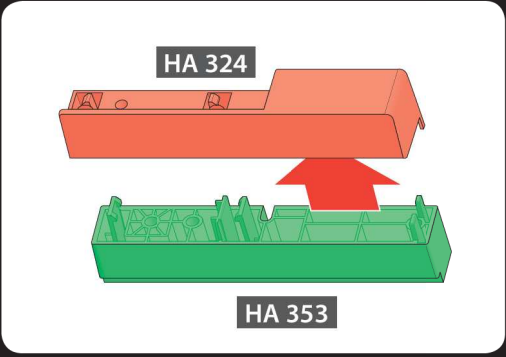
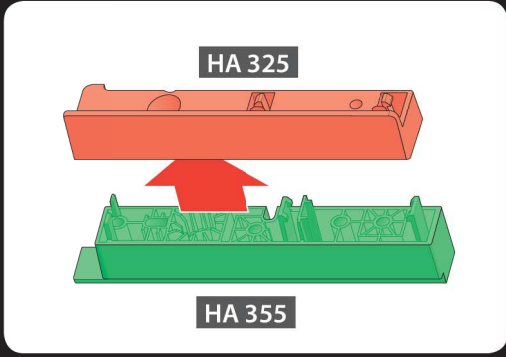
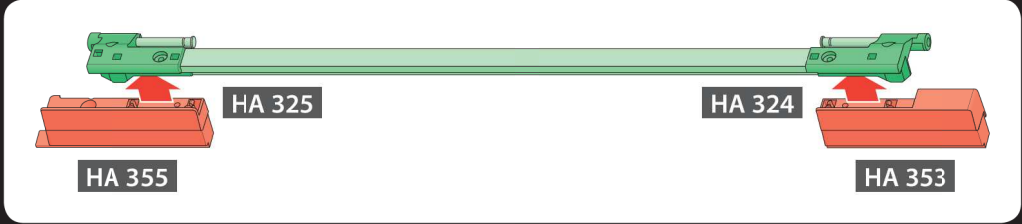



1

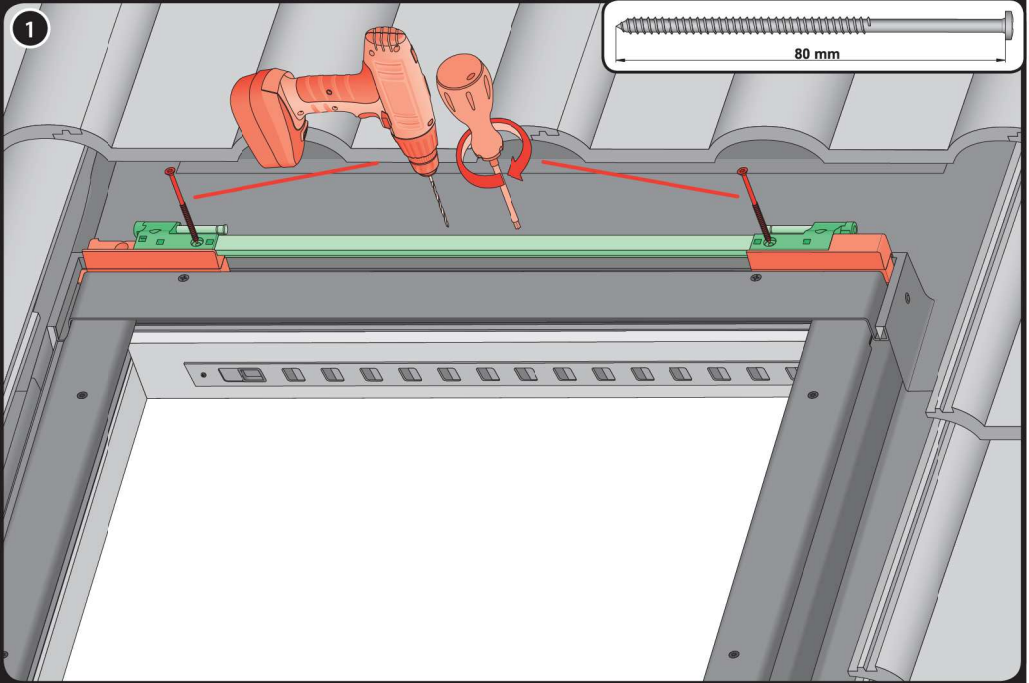

2

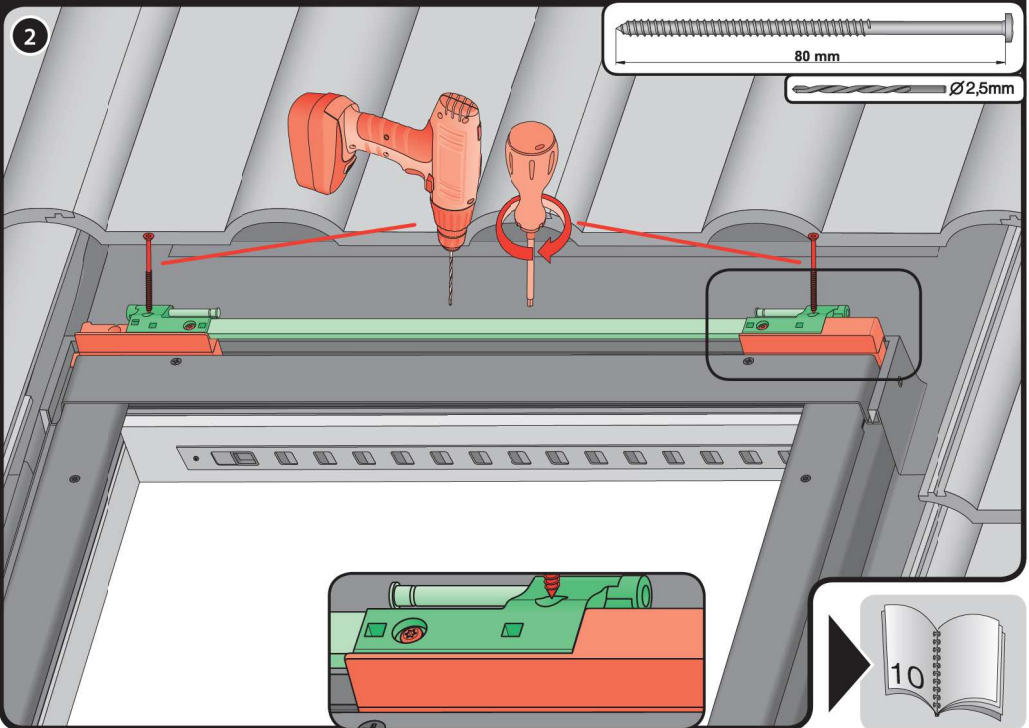

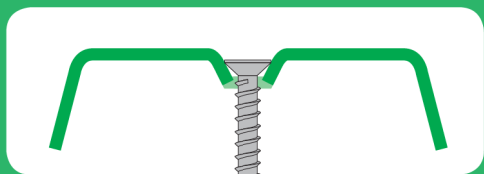
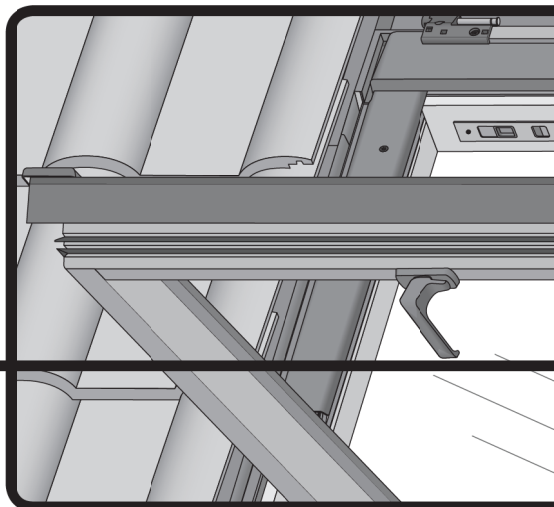
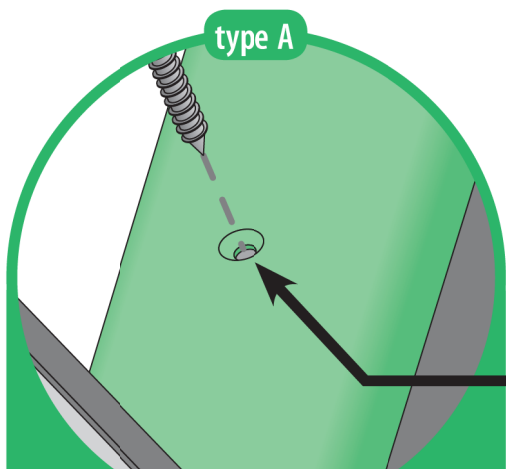

HA 328

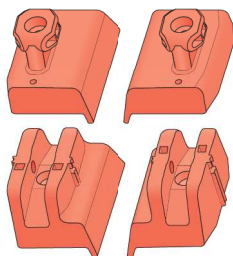

HA 329

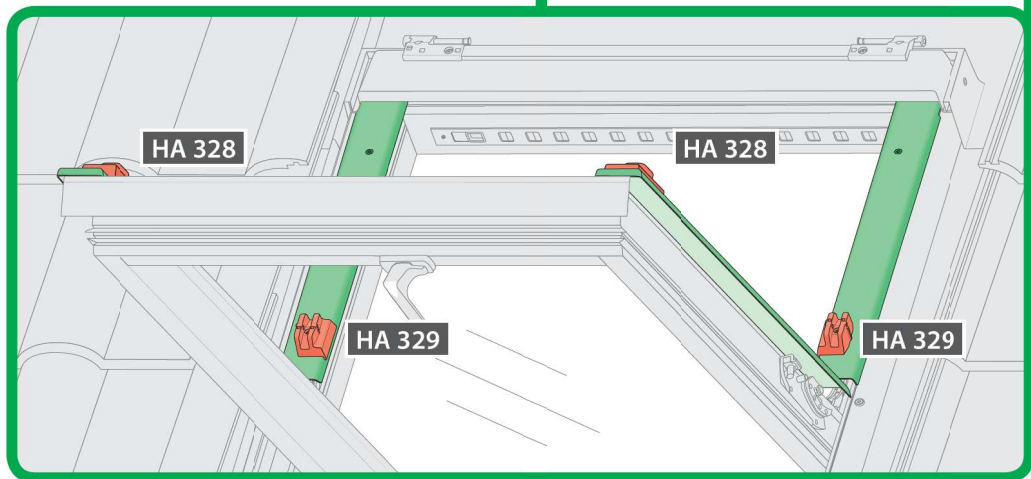

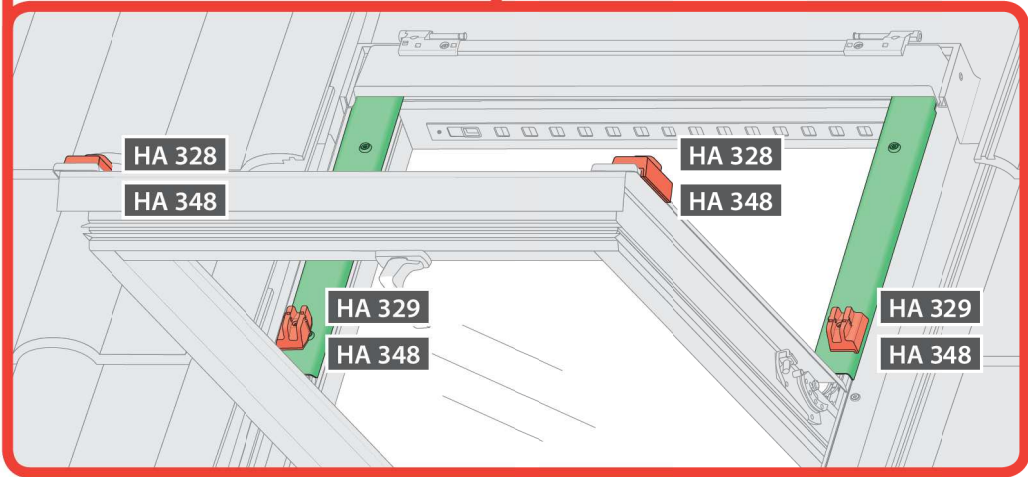
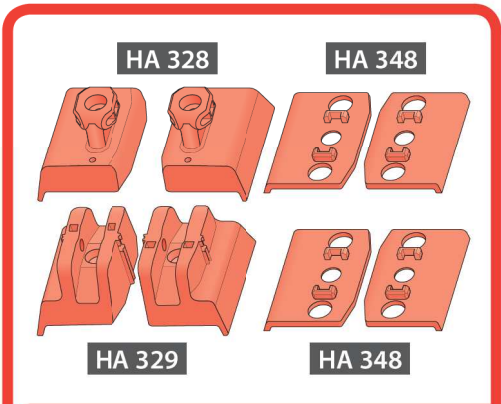
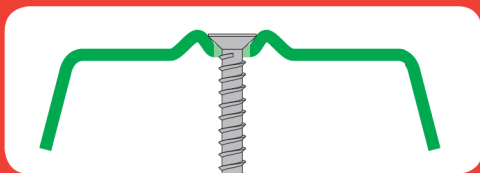
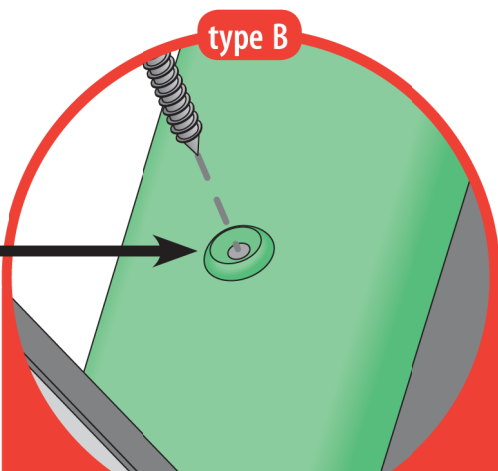
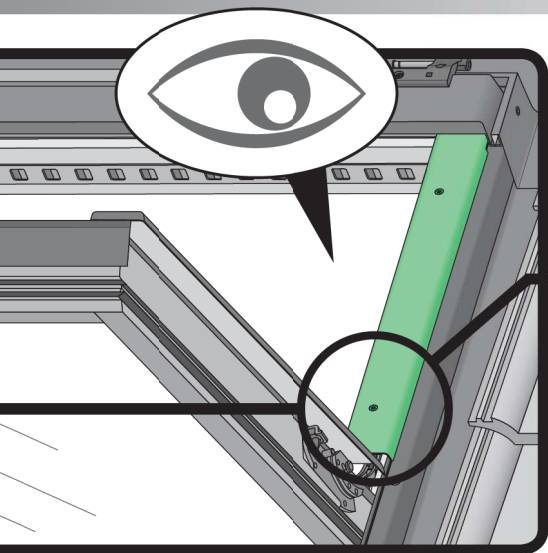

6

type A

1

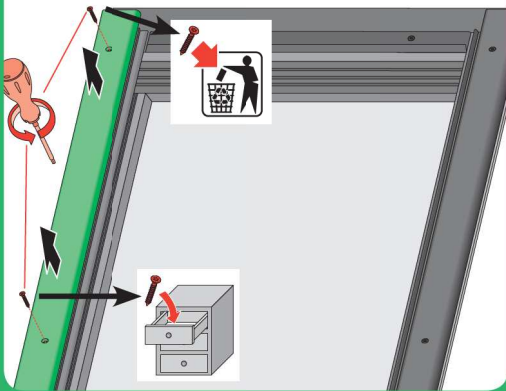

2

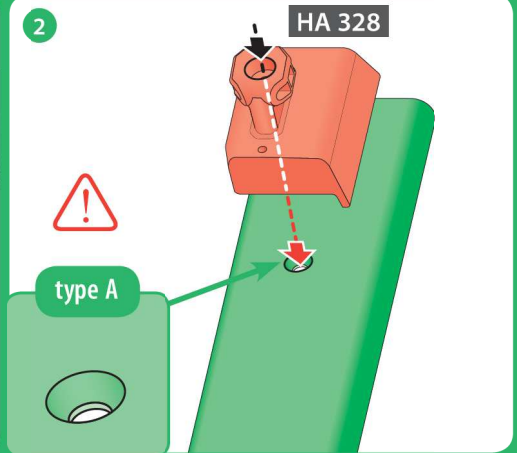

3

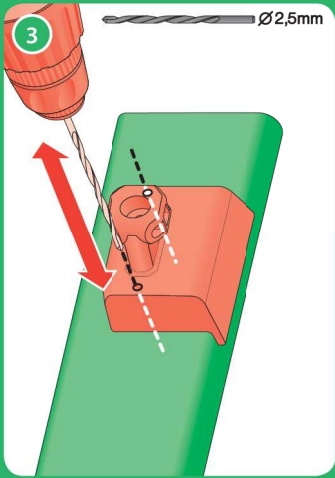

4



5

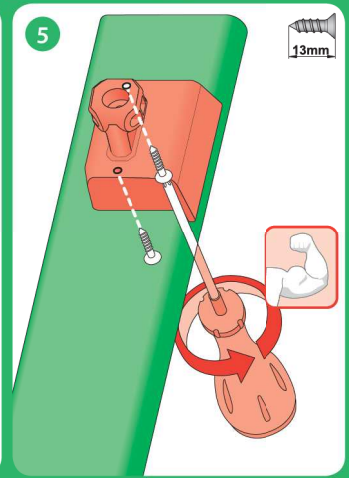

6

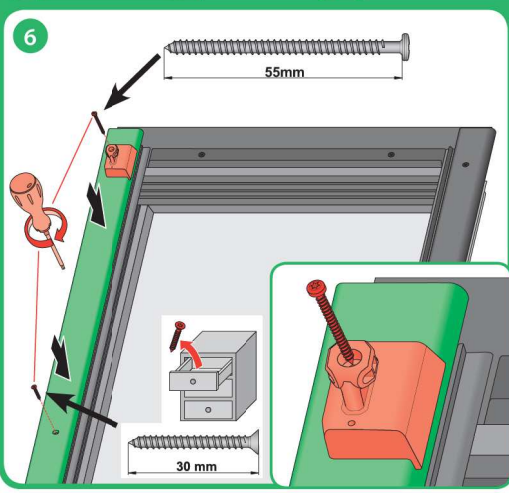

7

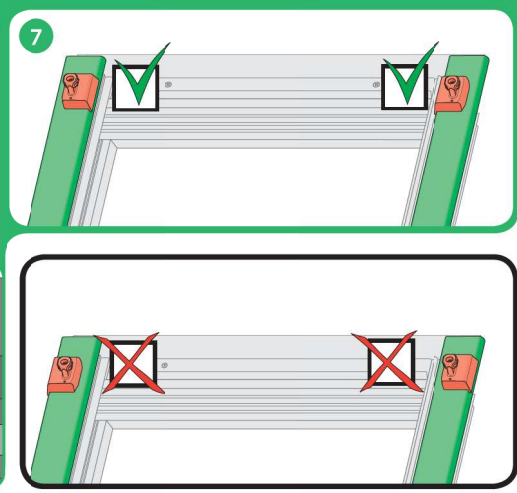

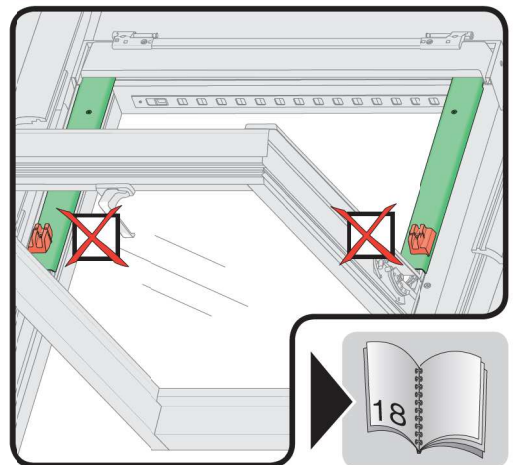
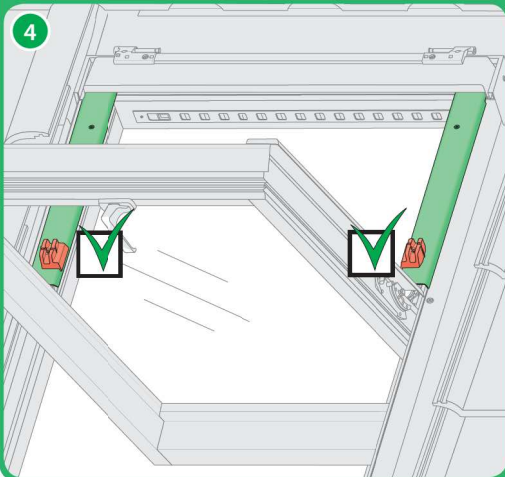
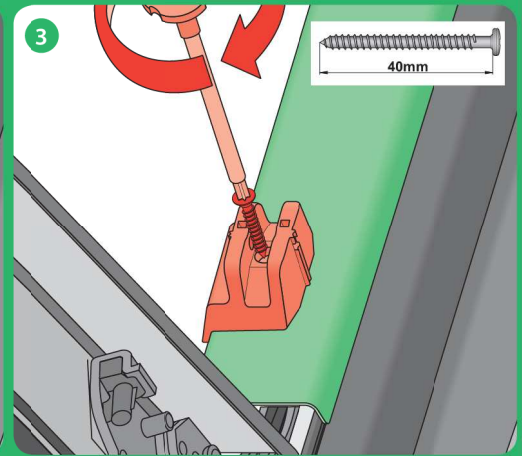
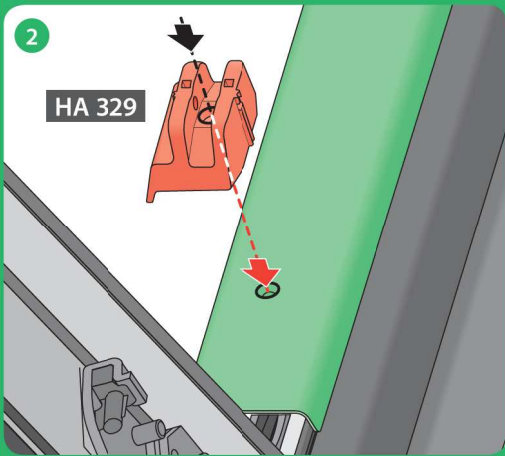
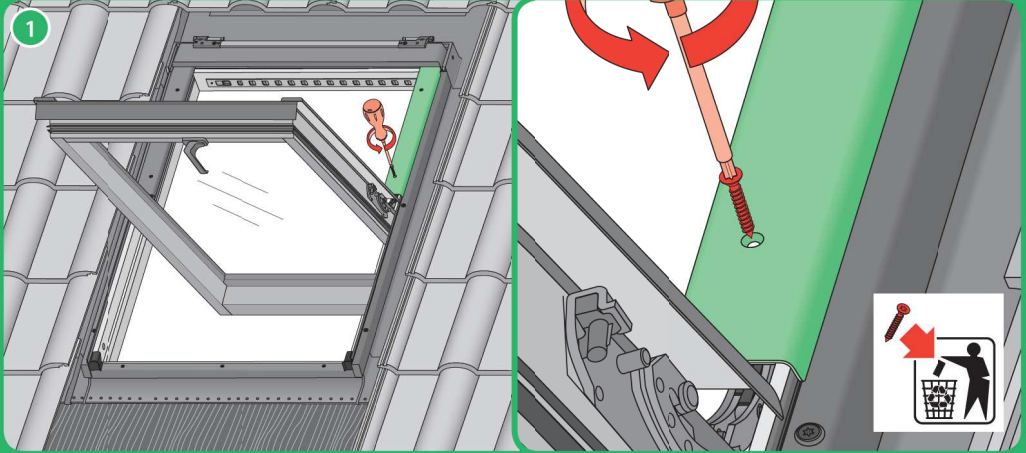

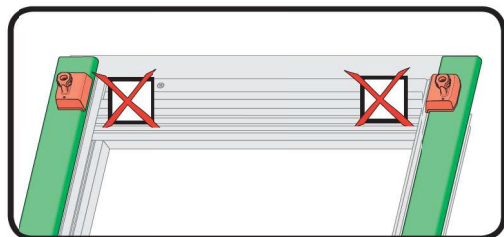
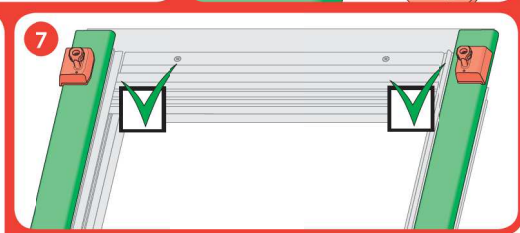
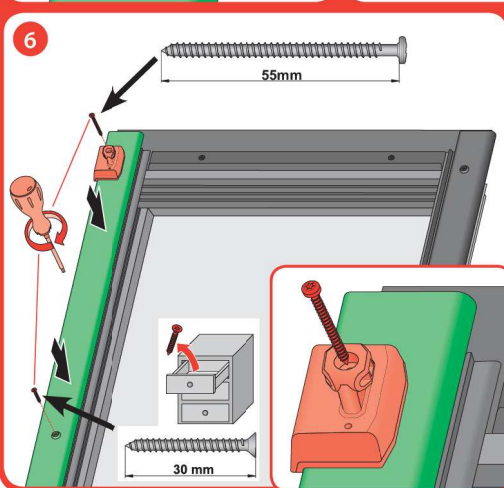
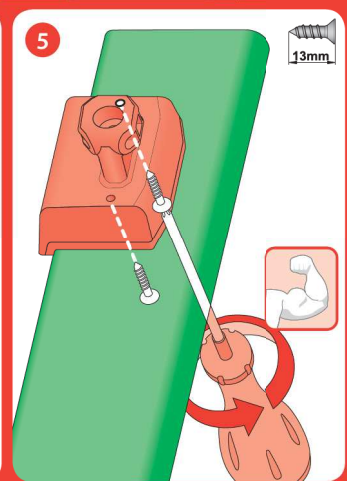
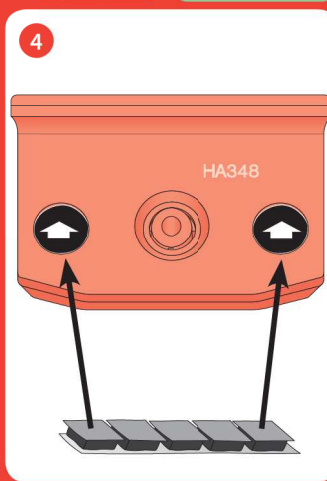
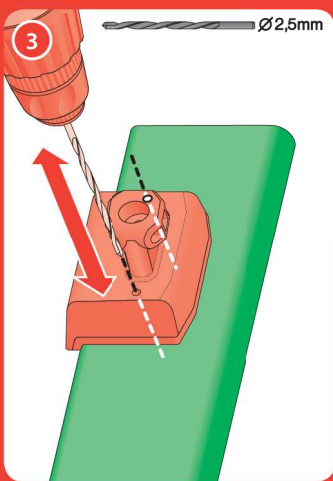
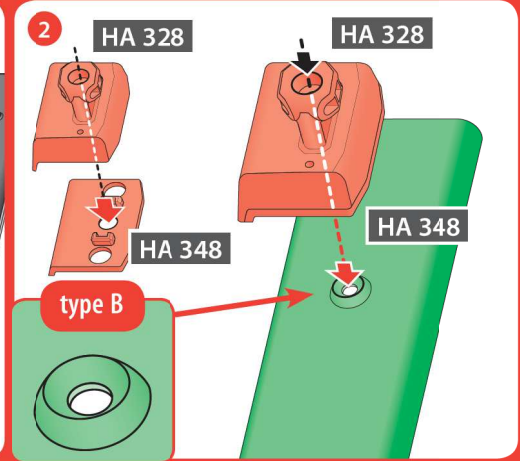
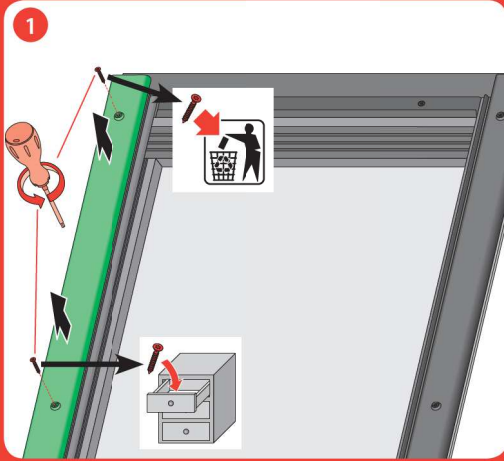

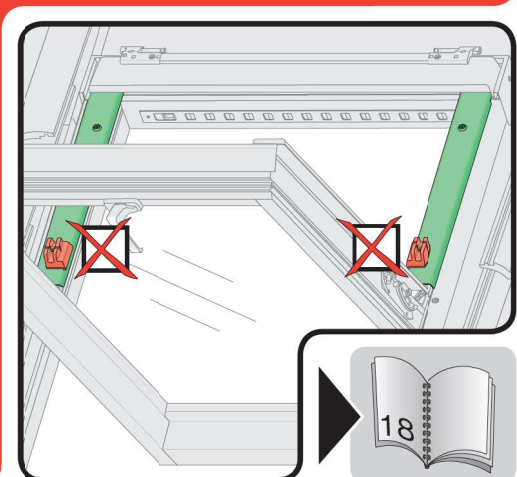
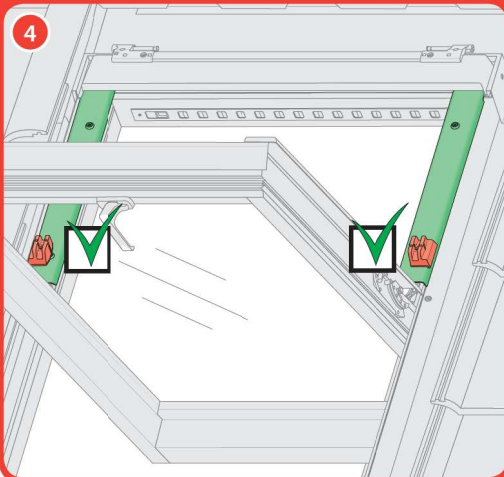
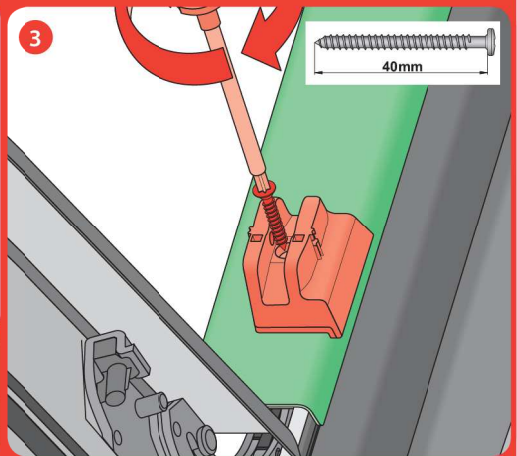
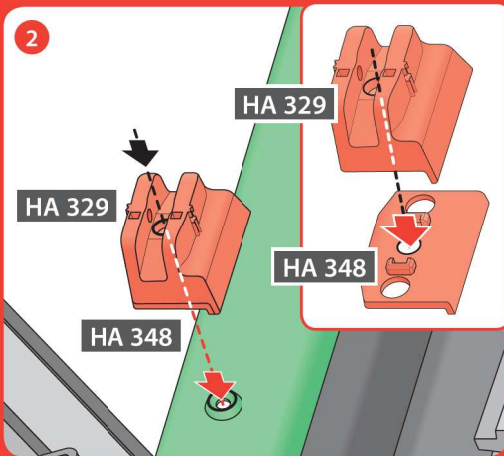
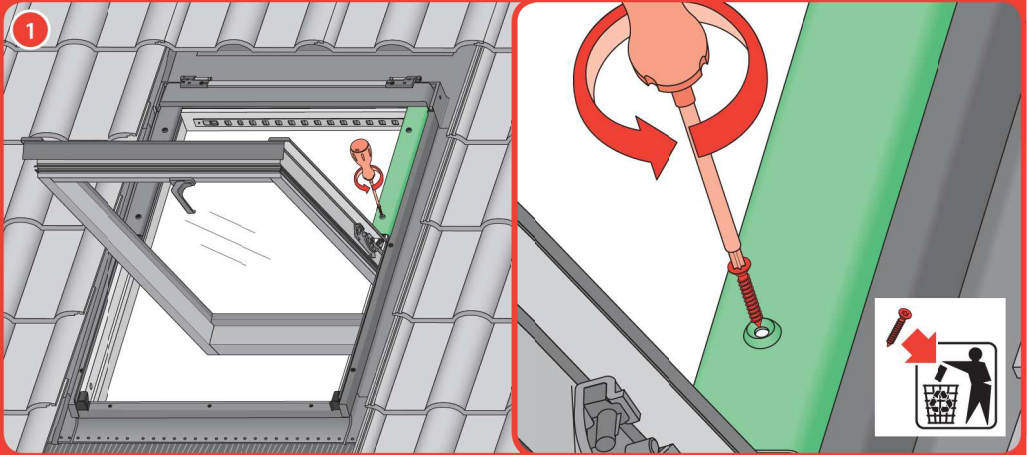

# □ FTP-V WiFi



8

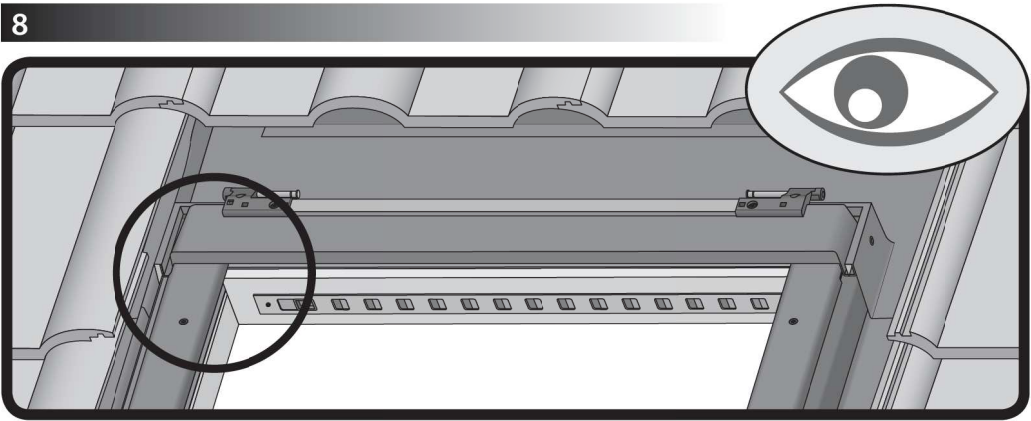

type A

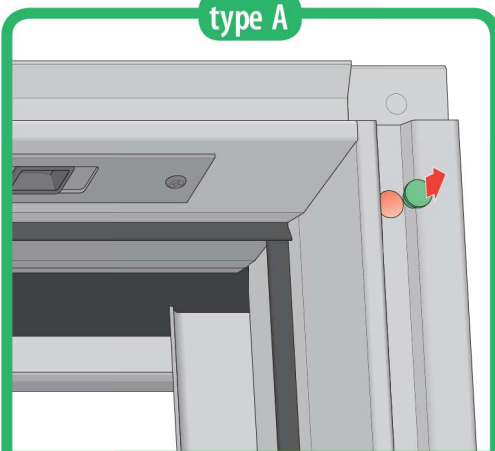

FTS, FTS-V, FTP, FTP-V, FYP, FYP-V  
FTT, FDY-V, FPP preSelect 2  
PTP, PTP-V, PYP, PYP-V



type B

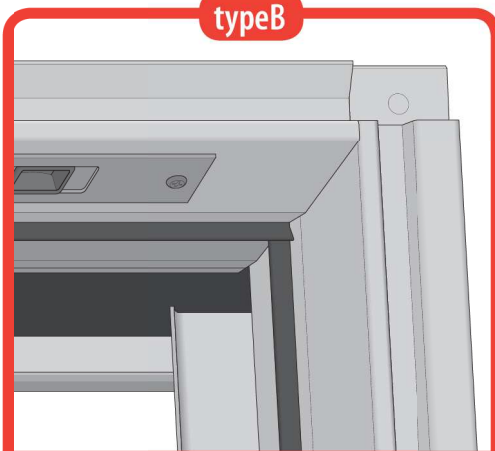

FTS, FTS-V, FTP, FTP-V, FYP, FYP-V  
FTT, FDY-V, FPP preSelect  
PTP, PTP-V, PYP, PYP-V





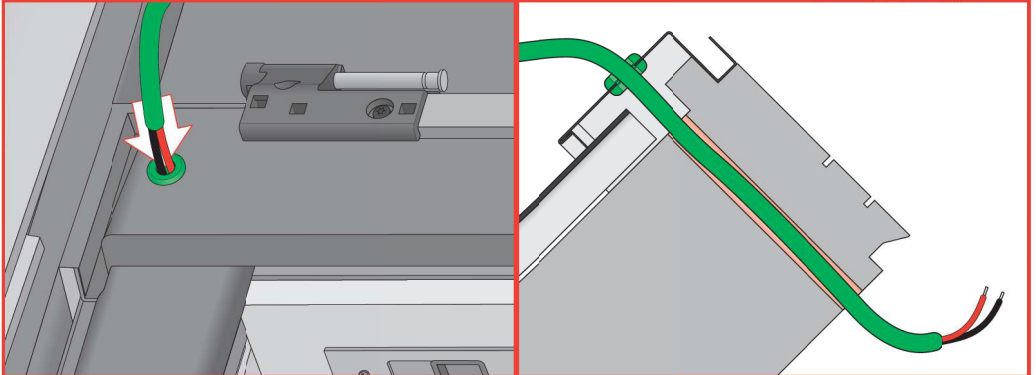
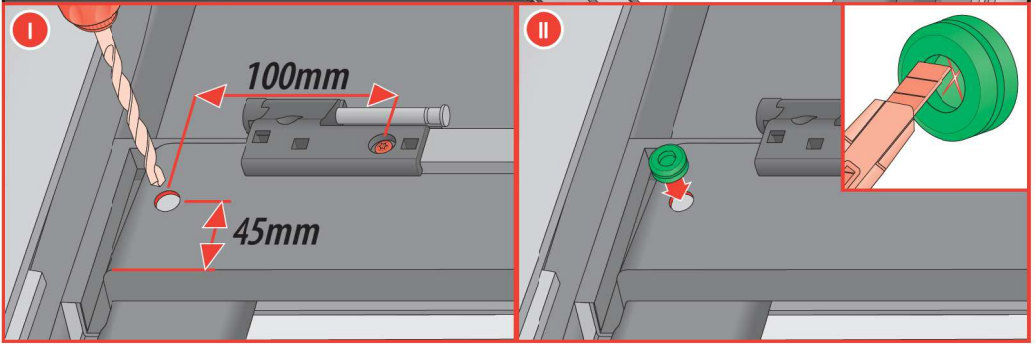
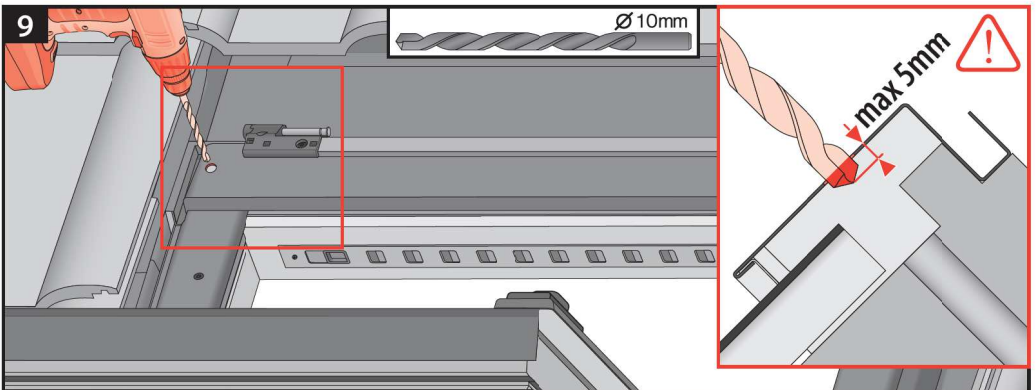

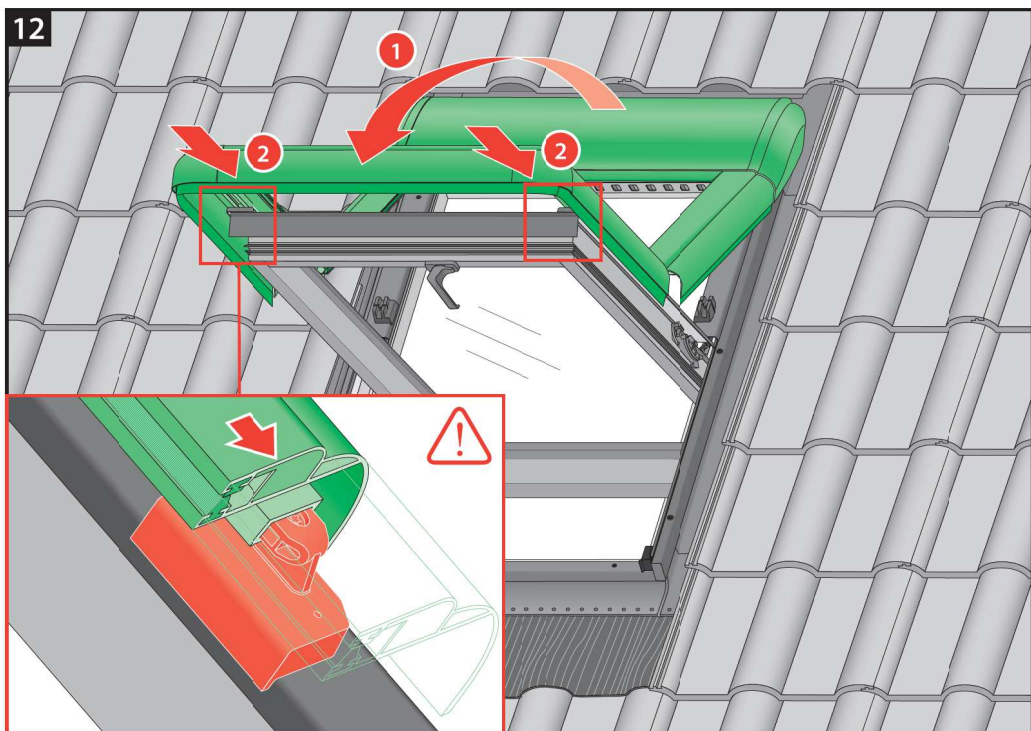
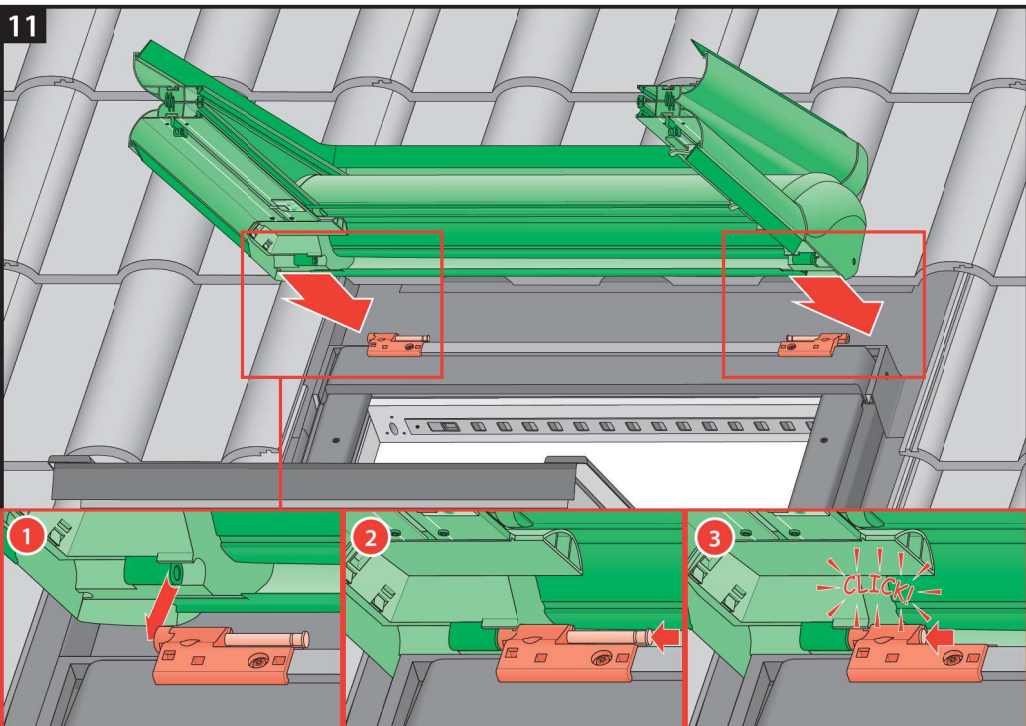

13

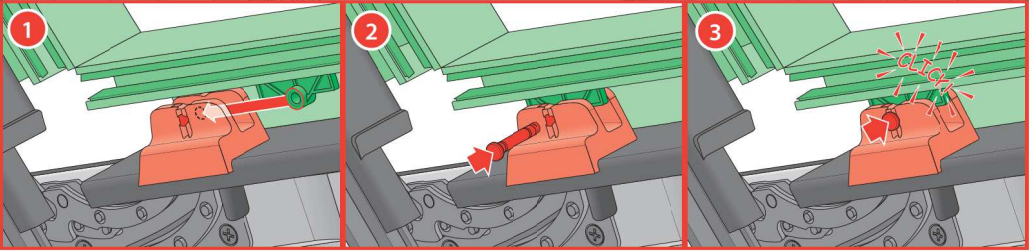
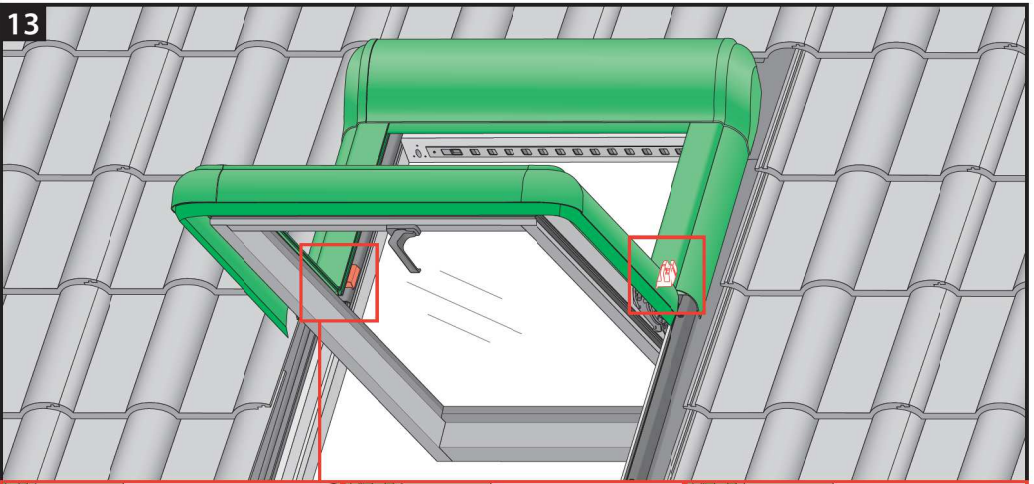

□ FTP-V WiFi → 

14

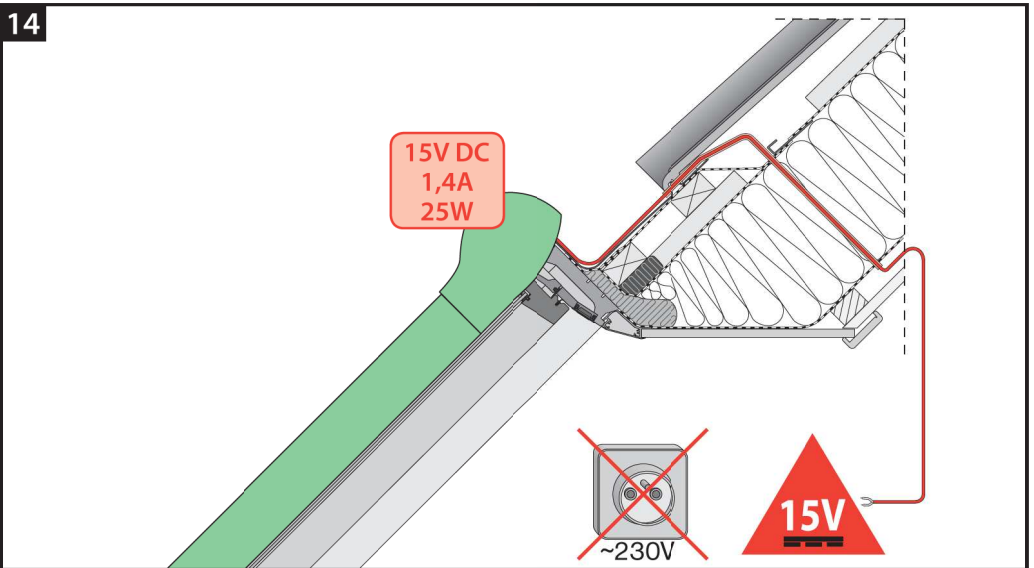

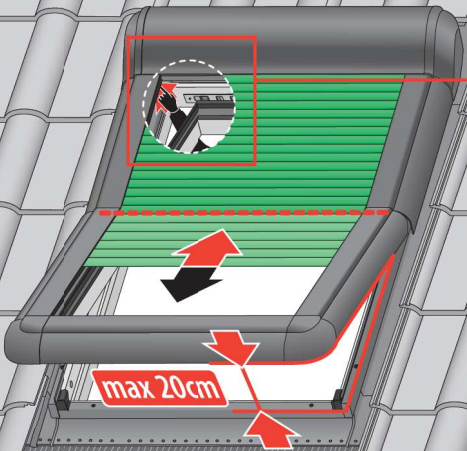
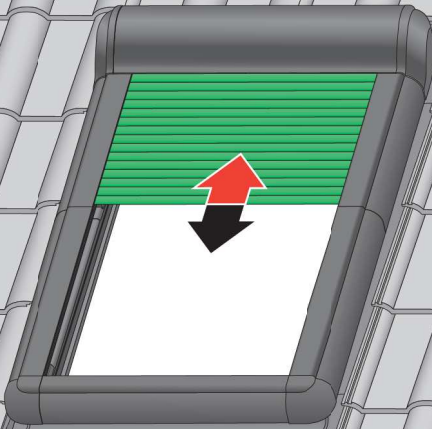

16



17

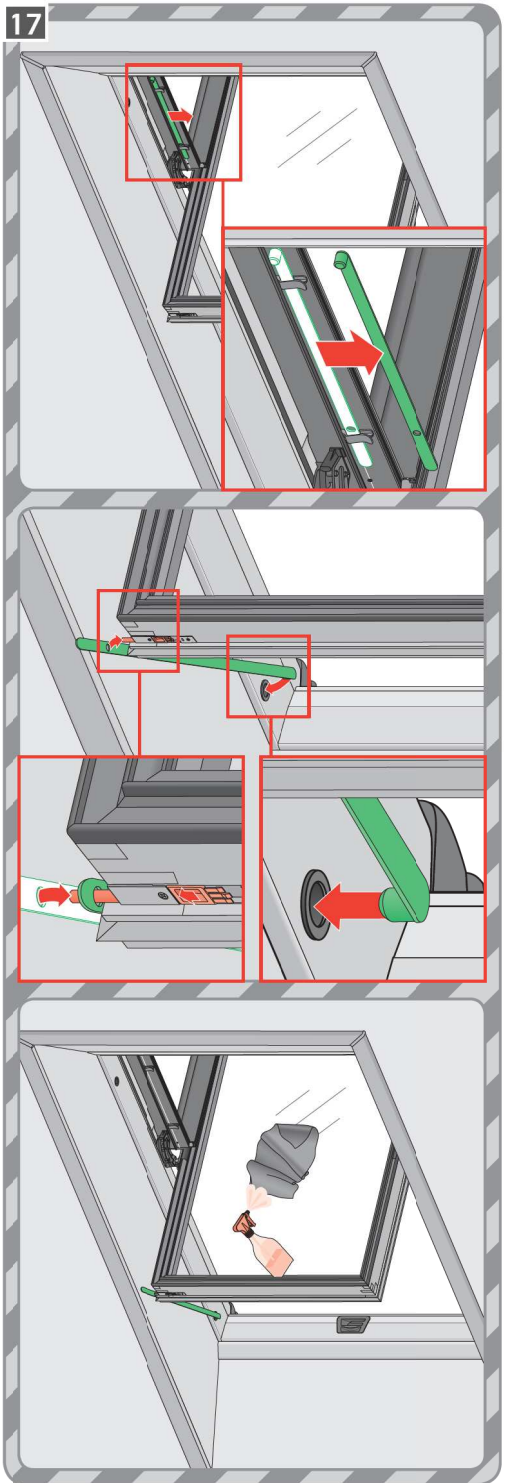

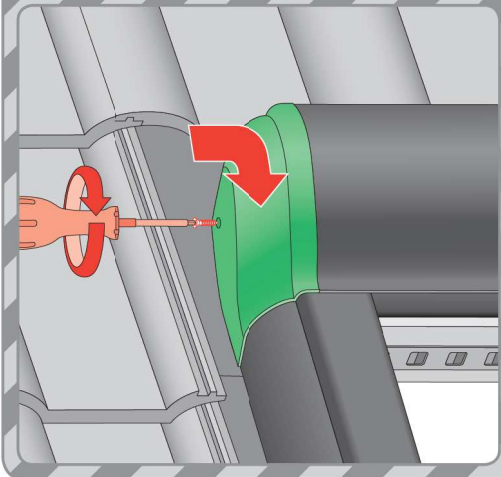
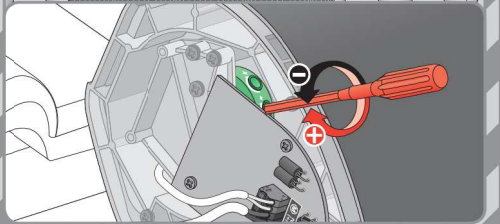
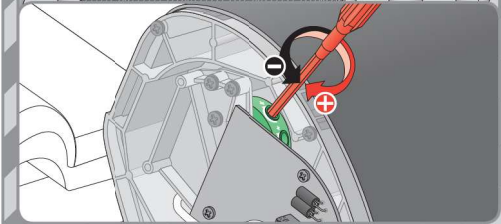
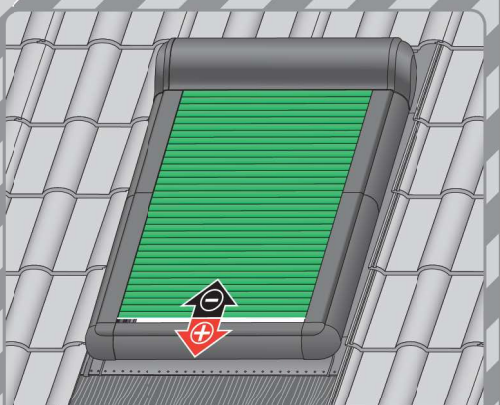
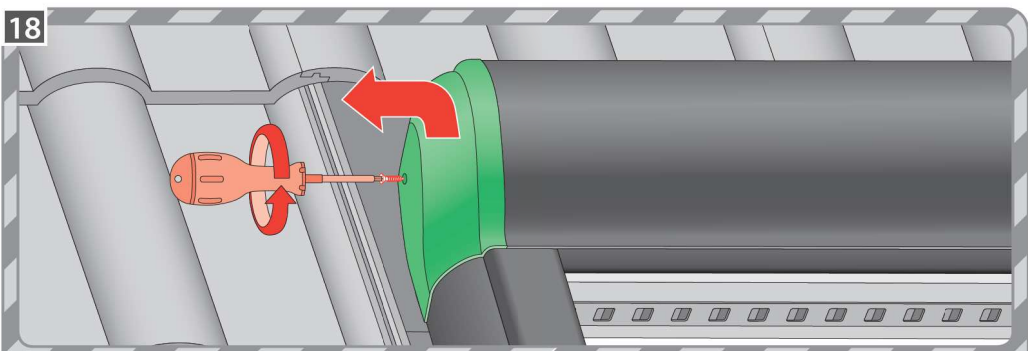

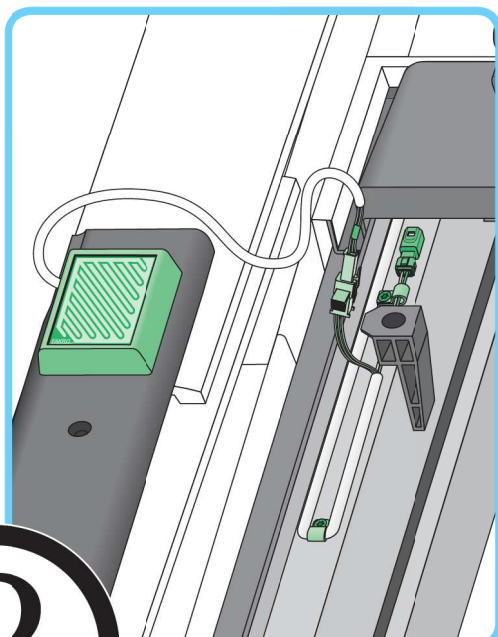
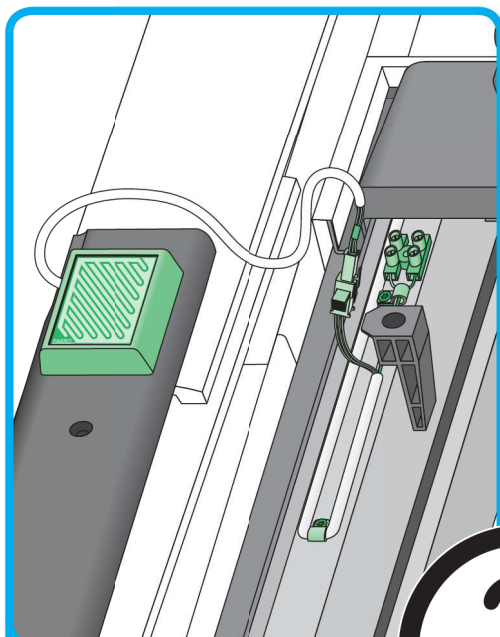
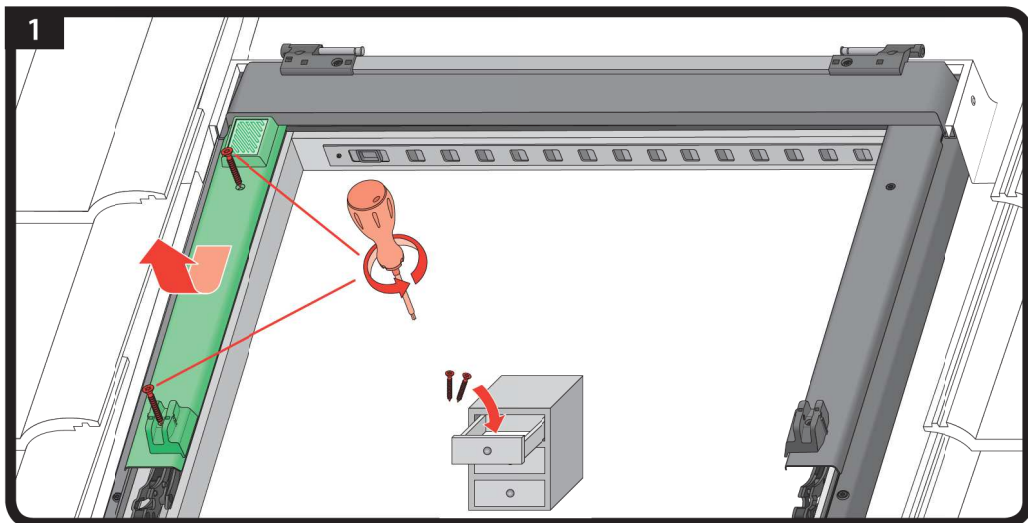

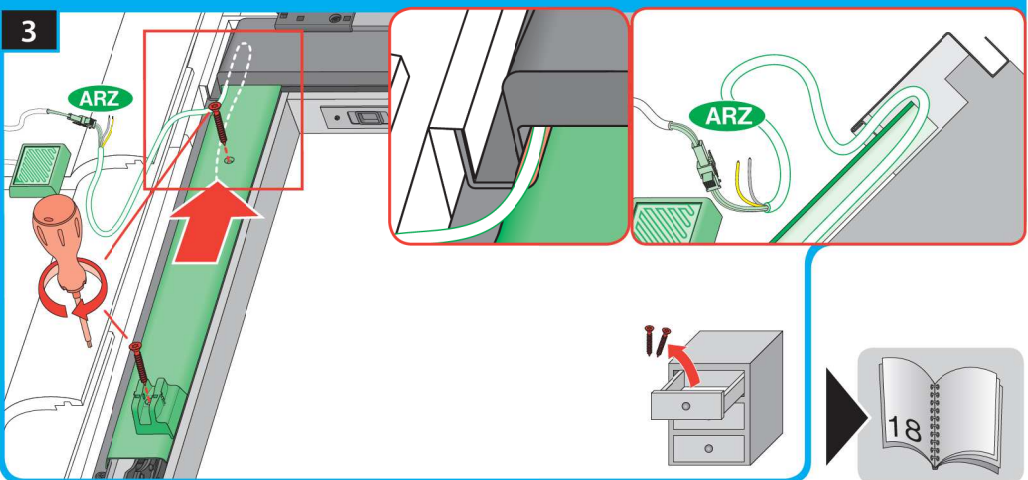
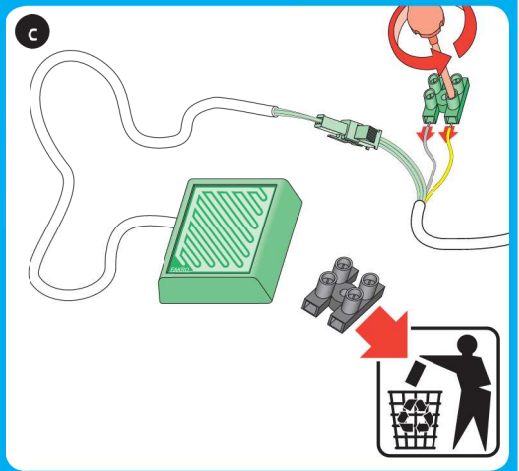
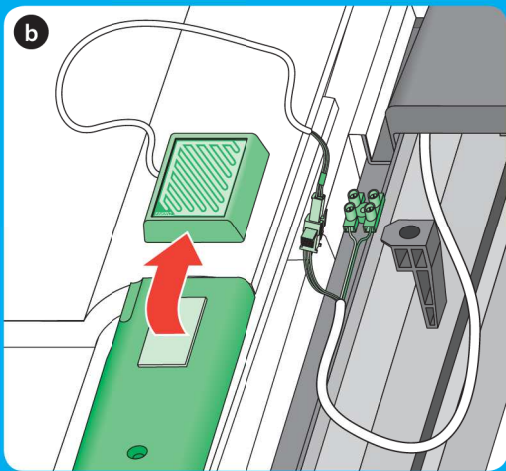
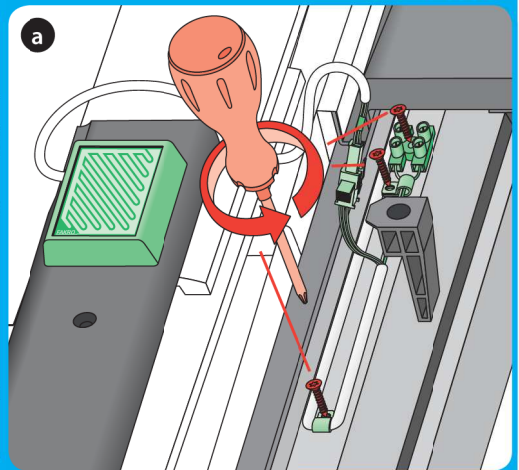
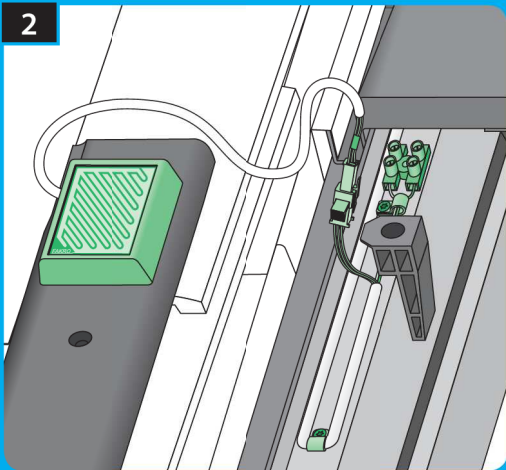



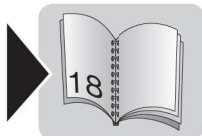
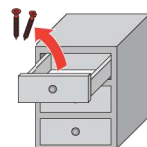
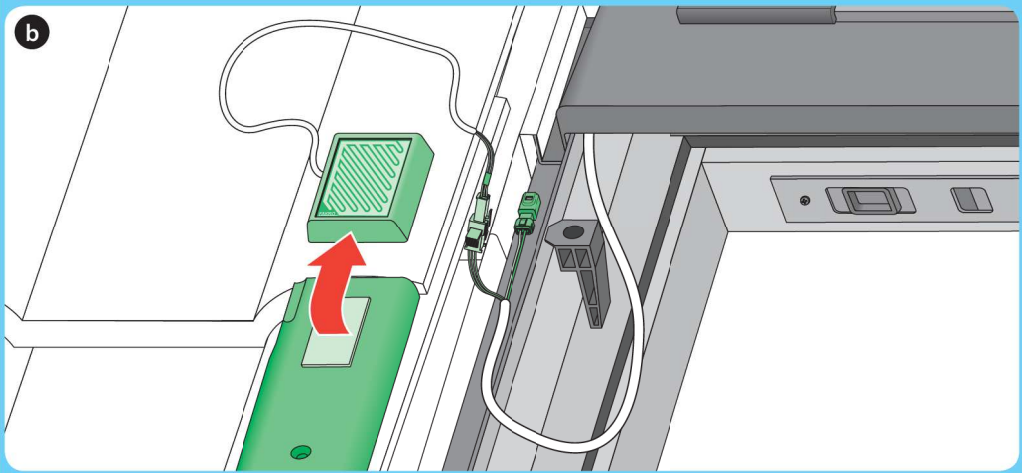
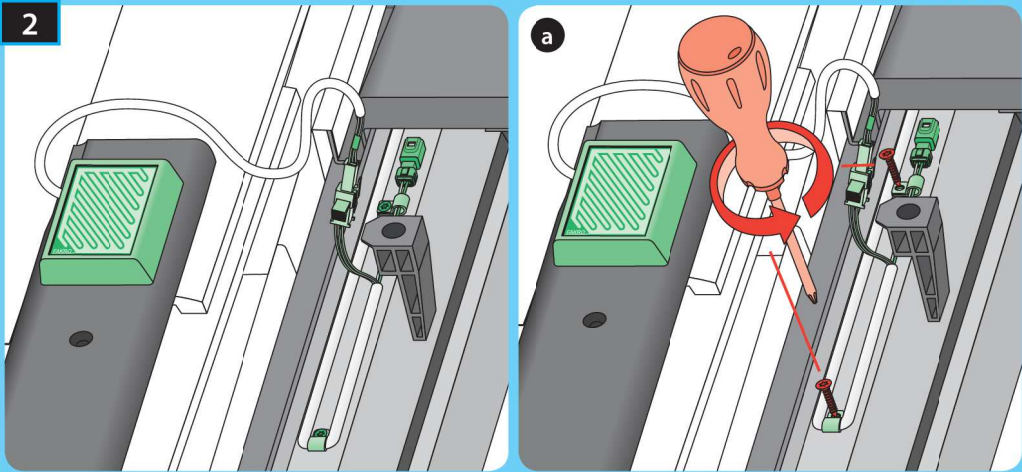

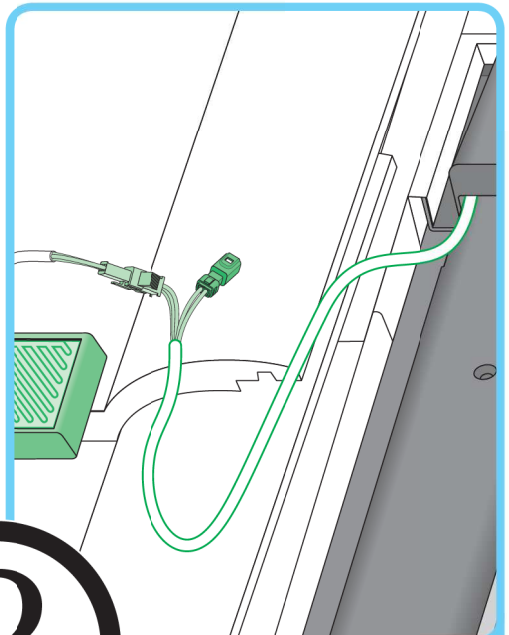
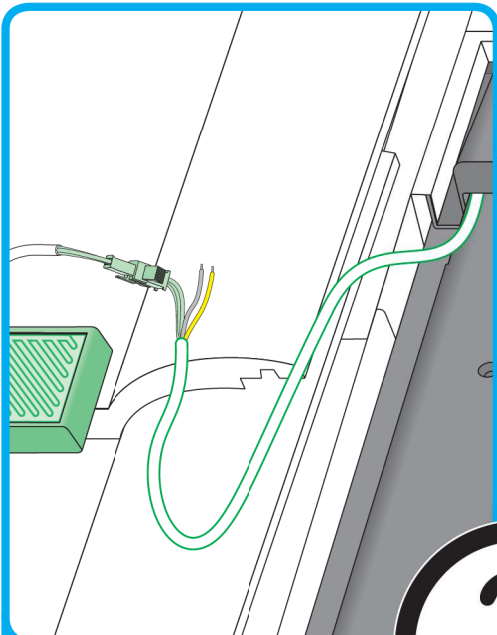
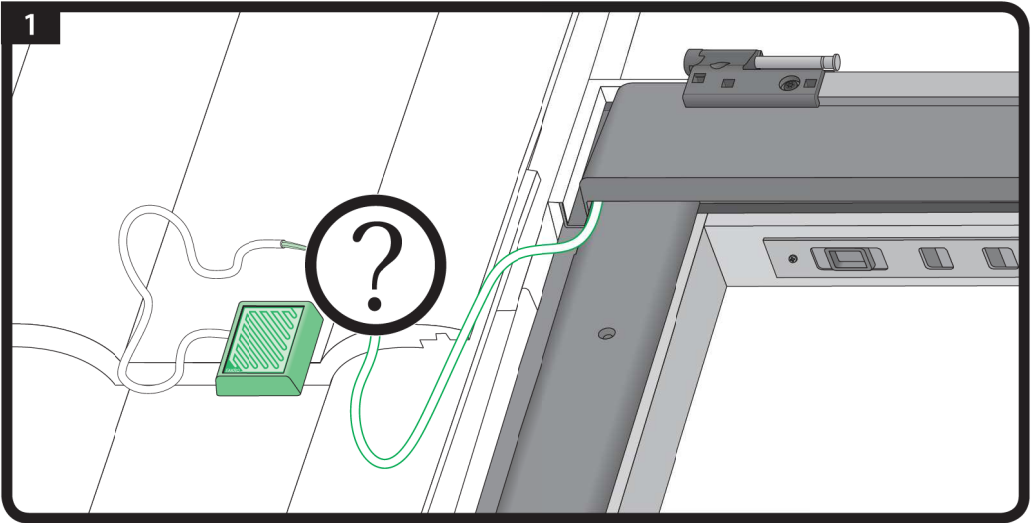

2

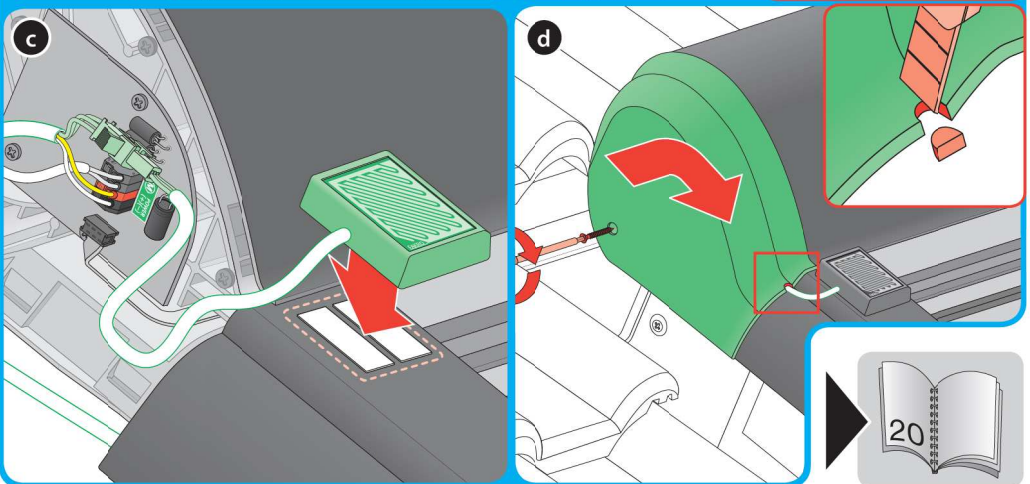
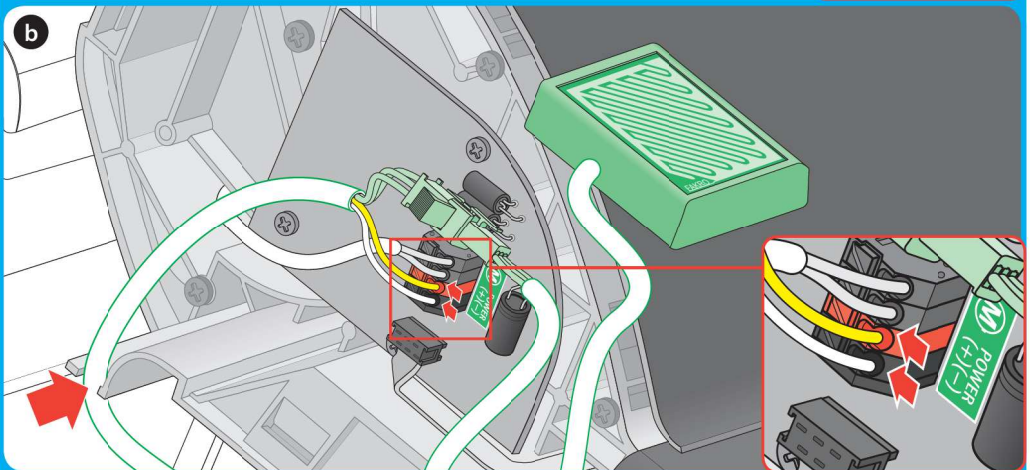
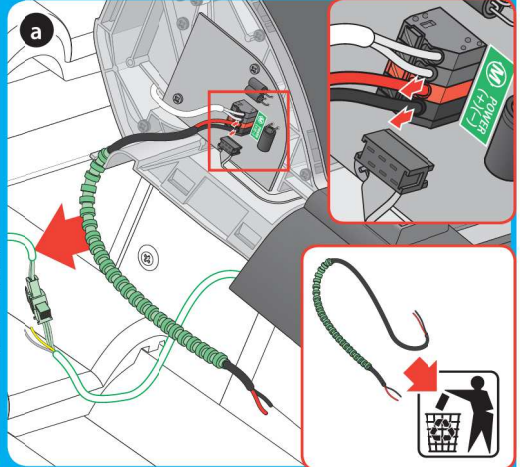
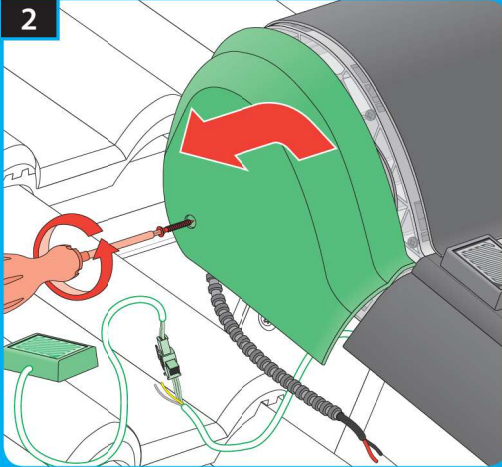

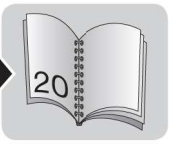
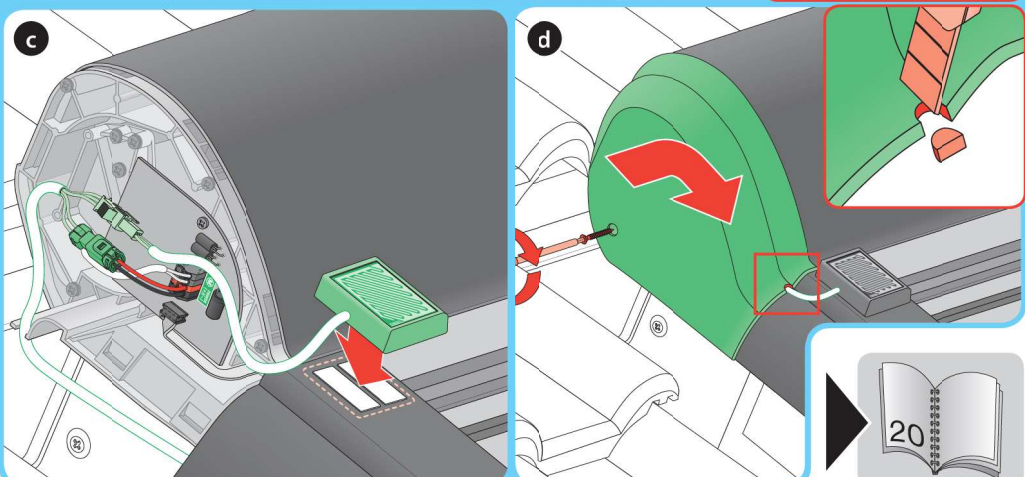
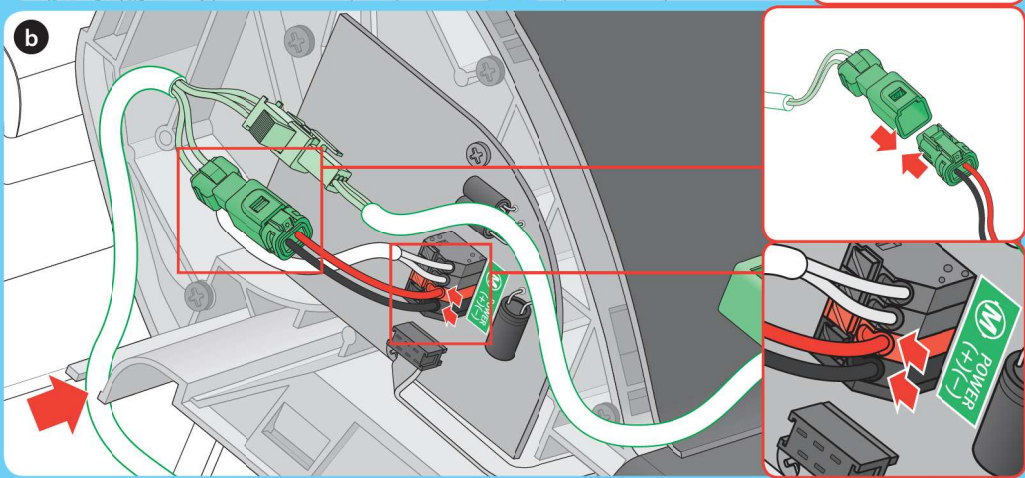
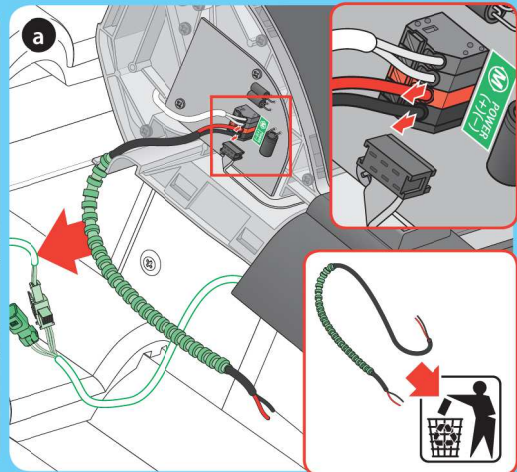
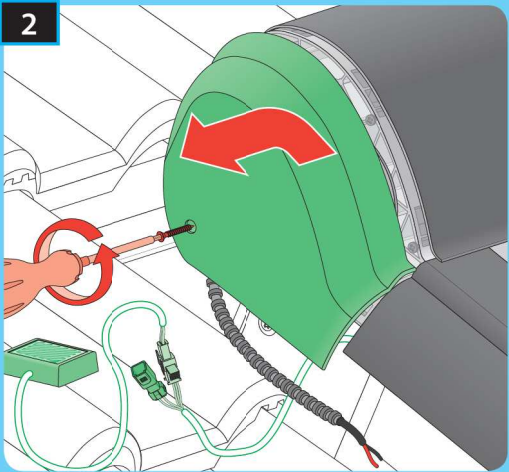

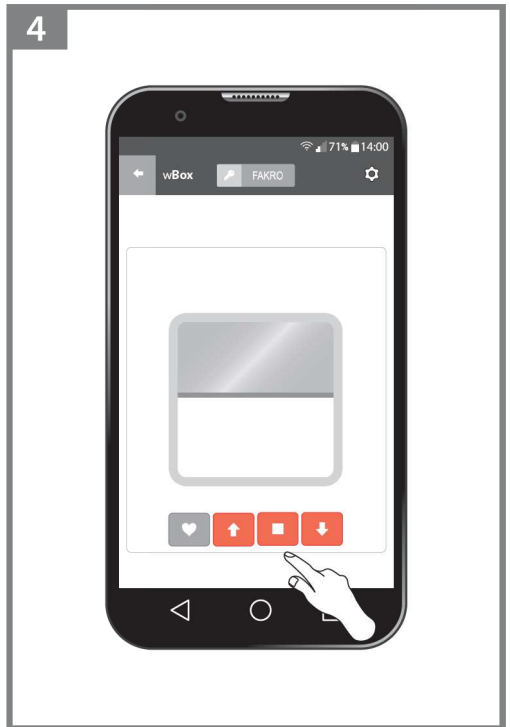
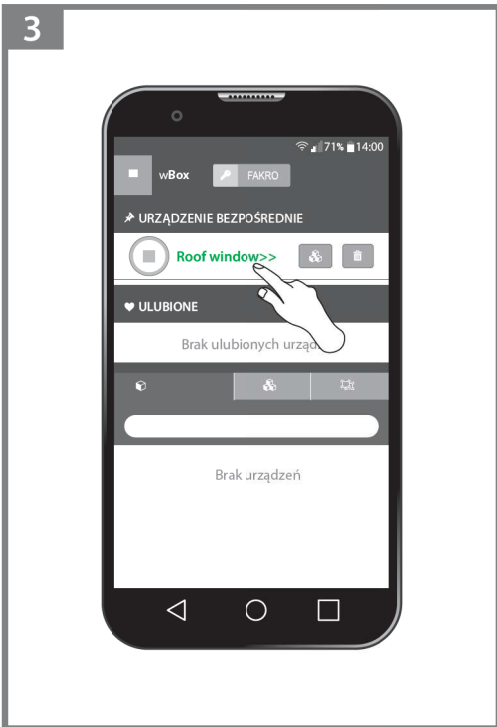





PL	Przed montażem należy zapoznać się z treścią instrukcji NC9LW „INSTRUKCJA ORYGINALNA 2/3 Zasady montażu i użytkowania”.
1	Wysunąć sworznie korpusu a następnie wyjąć zespół profilu montażowego z rolety.
2	Przygotować zespół profilu montażowego w zależności od rodzaju kaptura okna.
3	Nakleić kostki masy uszczelniającej w miejscach pokazanych na rysunku. W przypadku występowania niskiego kaptura lub kaptura z szeroką rynną zastosować dodatkowe podkładki montażowe.
4	Przykręcić zespół profilu montażowego do kaptura okna za pomocą wkrętów dołączonych do zestawu montażowego rolety.
5	Sprawdzić rodzaj przetłoczeń pod wkręty w profilach okna (type A lub type B).
6	Zamontować ślizgi dolne rolety do profili trapezowych okna. W razie potrzeby użyć dodatkowych podkładek.
7	Zamontować uchwyty suwaka do górnych profili trapezowych. W razie potrzeby użyć dodatkowych podkładek.
8	Sprawdzić, czy okno wyposażone jest w otwór pod przewód zasilający dodatek.
9	Wykonać otwór w kapturze a następnie umieścić w nim gumowy przepust.
10	Wsunąć przewód zasilający w otwór.
11	Nałożyć roletę na profil montażowy a następnie wsunąć sworznie zabezpieczające.
12	Nasunąć dolną część rolety na ślizgi dolne.
13	Wsunąć sworznie zabezpieczające w uchwyty suwaka.
14	Podłączyć roletę do sieci poprzez zasilacz 15VDC.
15	Sterować roletą za pomocą aplikacji wBox lub przycisków na rolecie. Maksymalny uchył okna z roletą przy rozwiniętym pancerzu to 20 cm.
16	Nie dopuszczać do nagromadzenia śniegu na rolecie, w tym celu zaleca się stosowanie urządzeń zapobiegających zsuwaniu się śniegu na roletę. Regularnie usuwać zanieczyszczenia, które mogłyby utrudniać pracę rolety.
17	Do zabezpieczenia okna w pozycji „do mycia” używać zaczepu zabezpieczającego.
18	W razie potrzeby przeprowadzić regulację pozycji krańcowych rolety.

EN	Before installation, it is compulsory to read the NC9LW „ORIGINAL INSTRUCTIONS 2/3 Installation and user manual”.
1	Slide out the casing pins and then remove the mounting profile unit from the shutter.
2	Prepare the mounting profile unit depending on the window hood type.
3	Stick sealing blocks in the places shown in the picture. Use additional mounting washers if there is a low hood or a wide gutter hood.
4	Fix the mounting profile unit to the window hood using the screws included in the shutter installation kit.
5	Check the corrugation type for screws in the window profiles (type A or type B).
6	Install the shutter bottom sliders to the trapezoidal profiles of the window. If required, use additional washers.
7	Install the silder holders to the upper trapezoidal profiles. If required, use additional washers.
8	Check whether the window is equipped with an opening for the power cable for the accessory.
9	Make an opening in the hood and then place a rubber cable penetration.
10	Slide the power cable into the opening.
11	Place the shutter on the mounting profile and then insert the safety pins.
12	Place the bottom shutter part on the bottom sliders.
13	Slide the safety pins into the slider holder.
14	Connect the shutter to the network using the 15VDC power supply.
15	Operate the shutter using the wBox app or buttons on the shutter. The maximum window opening with the shutter having the armour unfolded is 20cm.
16	Do not allow accumulation of snow on the shutter. For this purpose it is recommended to use devices preventing snow from sliding onto the shutter. Regularly remove any dirt that might obstruct operation of the shutter.
17	Use the safety catch to secure the window in the position for cleaning.
18	If required, adjust the end positions of the shutter.



BG	Производител и Продавач не носят отговорност за неспазване на съответните закони, строителни норми и изисквания за безопасност от ползвателя на продукта, архитекта, монтажника или собственика на сградата.
CZ	Uživatel ani prodávce nenesou odpovědnost za nedodržení příslušných právních zákonů, stavebních předpisů a bezpečnostních požadavků výrobce, architektů, montážníků nebo vlastníků budovy.
DE	Hersteller und Verkäufer übernehmen keine Haftung für Nichtbeachtung entsprechender Rechts- und Bauvorschriften sowie Sicherheitsanforderungen seitens Produktbenutzers, Architekten, Monteurs oder Gebäudebesitzer.
ES	El fabricante y el vendedor no tienen ninguna responsabilidad por el incumplimiento de la ley vigente, normas de construcción y exigencias de seguridad por parte del usuario del producto, arquitecto, instalador o el propietario del edificio.
FR	Le fabricant et le vendeur ne prend aucune responsabilité de ne pas respecter les lois applicables, les règlements sur les bâtiments et les exigences de sécurité par l'utilisateur du produit, l'architecte, l'installateur ou le propriétaire du bâtiment.
GB	Manufacturer and Seller shall bear no liability for failure to comply with the applicable laws, building codes and safety requirements by the user of the product, architect, fitter or owner of the building.
HU	A gyártó és a forgalmazó nem vállal semmilyen felelősséget a vonatkozó törvények, építési és biztonsági előírások, a gyártó és a felhasználó által be nem tartásáért.

IT	Il Produttore e il Rivenditore non potranno essere ritenuti responsabili per il mancato rispetto, da parte dell'utente del prodotto, dell'installatore o del proprietario dell'edificio, delle leggi vigenti, nonché dei regolamenti edili e di quelli relativi alla sicurezza.
NL	De fabrikant en verkoper zijn niet aansprakelijk voor gevolgen bij het niet opvolgen van toepasselijke wetten, bouwvoorschriften en veiligheidsvoorschriften door de gebruiker van het product, de architect, de installateur of de eigenaar van het gebouw.
PL	Producent i Sprzedawca nie ponosi żadnej odpowiedzialności za nieprzestrzeganie stosownych przepisów prawa, przepisów budowlanych i wymogów bezpieczeństwa przez użytkownika produktu, architekta, montażystę lub właściciela budynku.
PT	O fabricante e o vendedor não tem nenhuma responsabilidade pelo o não cumprimento da lei, códigos de construção e as exigências de segurança por parte do usuário do produto, arquiteto, instalador ou proprietário do edifício.
RO	Nici producătorul, nici distribuitorul nu își vor asuma niciun fel de răspundere pentru nerespectarea legilor în vigoare a legilor din domeniul construcțiilor sau a măsurilor de siguranță impuse utilizatorilor produsului, arhitecților, montajorilor sau proprietarilor clădirii.
RU	В случае несоблюдения архитектором, монтажником или владельцем здания строительных правил и норм безопасности ответственность за производитель и продавца снимается.
SK	Vníkajúca a predávajúca strana zodpovedá za nedodržanie príslušných ustanovení zákona, stavebných predpisov a bezpečnostných požiadaviek užívateľom výrobku, architektom, montážnym dielom majiteľom objektu.